

Think Trespa

Experience



PASSIVE HOUSE

Building the largest Passive House development in the Netherlands.

Imagine



CURIOSITY AND DESIGN

The curious case of Trespa Design Centre New York.

Build



FIRE BEHAVIOUR

Professor Paul Vandevelde and how fire behaves in buildings.

Trust



UNI COLOURS

Introducing 9 new Inspiring Trespa® Meteon® colours.



JESS PAULL

THERE IS A METHOD
TO THE MADNESS

New storytelling colours

Introducing 9 new Trespa® Meteon® Uni Colours.

COLOUR EVOKES EMOTION AND WITH IT MEMORIES OR IDEAS ABOUT THE FUTURE. EACH COLOUR IS AN ABSTRACT NOTION OF THE WORLD THAT LIES BEYOND. WORKING IN CLOSE COLLABORATION WITH CREATIVE PROFESSIONALS, TRESPA HAS DEVELOPED NINE NEW FRONT COVERS FOR THE FUTURE, EACH ONE REFLECTING A VIEW OF THE WORLD. NINE NEW COLOURS THAT LET YOU CREATE, REVEAL AND DESIGN A FAÇADE THAT HAS A STORY TO TELL.



Think Trespa

TRESPA®



With today's speed of communication it is very easy to get information. We love our convenient electronic devices – our smartphones and iPads. Nevertheless, it feels so good to, once in a while, turn over the pages of a real paper magazine. One that shows inspiring images and tell the rich story behind them. With this first issue of our magazine Think Trespa, we would like to offer you, our clients and followers, a magazine that presents in-depth knowledge in addition to our new website. Made to inform our industry, it covers a wide range of topics, from product innovation to new service solutions, business concepts and the very latest trends.

When you talk to any of our staff, you will instantly notice that we are passionate about our products. It is precisely this passion that we would like to share. As a market leader in façade products, active in over 50 different countries worldwide, we believe our job doesn't finish with producing good façade panels. Trespa knows how to make an attractive façade and wants to help architects and installers realise durable and outstanding ones.

“...we are passionate about our products. It is precisely this passion that we like to share...”

We purposely chose the style of the magazine to be bold and colourful, which I believe reflects the position of our company in the market. Trespa is an expert in 'colouring the world', we can supply a building's façade with any colour you like, creating façades that tell a story. Please enjoy reading this first issue and we look forward to inspiring you with many more in the future. Read this magazine as an invitation for your architectural design to be featured in our next issue.

Aart Jan van der Meijden
Commercial Director, Trespa International B.V.

CONTENTS

Experience

06, 08, 18, 19
REFERENCES

- ▶ Cultural centre, Spain
- ▶ European Ceramics Centre, France
- ▶ ResMed Laboratories, USA
- ▶ Rehabilitation Centre, Netherlands

12
**BOLD, GUTSY
AND VIBRANT**



Student accommodation makes a big impression on a British seaside resort

48
**PASSIVE
HOUSING**



Building the largest Passive House development in the Netherlands

Imagine

42
**THE CURIOUS
CASE OF THE
DESIGN CENTRE**



56
TRESPA STUDIO



A passion for product development and façade solutions

64
TRESPA
DESIGN CENTRES
EVENTS

New York, Santiago and Barcelona

Build

24
SUSTAINABILITY
AND TRESPA



Do No Harm, Do Good, Do Better

28
**HOW FIRE
BEHAVES**



Professor Paul Vandeveld explains how fire behaves in buildings

38
ENDURING THE
TEST OF TIME

In today's architecture, longevity is a key consideration

52
VENTILATED
FAÇADES

Inspired by natural systems

Trust

10, 22, 34, 46, 55, 61
**NEW UNI
COLOURS**



Colours that evoke emotion, memories and ideas about the future

35
TS700



A simple fixing system that opens up a world of design possibilities

More

Live
20
**THE IDEAS FACTORY
AND ITS
INNOVATIONS**

The encouragement and development of ideas

66
**COLOURING THE
WORLD**

A pallet of over 105 different colours to choose from

65
NEXT ISSUE

CA DON JOSÉ CULTURAL CENTRE

THE RAINBOW LIBRARY

A RAINBOW OF BRIGHT COLOURS ON THE 'COVER' OF THIS CULTURAL CENTRE EMBODIES ITS MULTITUDE OF USES. IN ADDITION, THIS COLOURFUL COLLAGE ABOVE THE DOOR INVITES PASSERSBY TO WANDER IN AND DISCOVER THE LATEST EXHIBITION, LIBRARY OR EVENT.



Canals, Spain



About the Project

ARCHITECT
HECTOR LUENGO ARQUITECTOS

INSTALLER
NANDO CARDONA DE LA CRUZ

MARKET SEGMENT
FAÇADE – PUBLIC BUILDING

YEAR
2011

PRODUCT
TRESPA® METEON®
UNI COLOURS

A05.0.0	A08.8.1	A12.3.7	A04.0.2
A04.1.7	A10.1.8	A20.2.3	A22.4.4
A17.3.5	A23.0.4		

FINISH
SATIN

FIXING SYSTEM
TS700 VISIBLE (EXPOSED) FIXING
WITH RIVETS ON A METAL
SUBFRAME

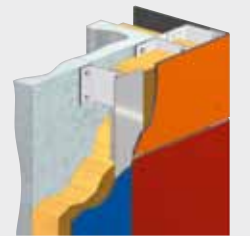

EUROPEAN CERAMICS CENTRE

TRAPEZIUM IN DEEP THOUGHT

STEEP INCLINING FAÇADES DEFINE THE INVERTED TRAPEZIUM FORM OF THIS CERAMIC RESEARCH CENTRE IN FRANCE.

THE PROJECT'S DESIGN WAS INFLUENCED BY THE SCIENTIFIC RESEARCH THAT WOULD BE CARRIED OUT WITHIN. DEEP-BLACK HIGH-QUALITY PANELS ARE USED TO CREATE A BUILDING THAT LOOKS SILENT AND IN DEEP THOUGHT. DISTINCTIVE STRAIGHT LINES AND ANGLES ARE USED TO REPRESENT BOTH THE MEASUREMENTS MADE AND ACCURACY REQUIRED FROM THE RESEARCHERS.



Limoges, France



About the Project

ARCHITECT

ATELIER JEAN DUBUS

INSTALLER

RAIMOND SAS & SMAC ACIEROID

MARKET SEGMENT

FAÇADE – PUBLIC BUILDING

YEAR

2009

PRODUCT

TRESPA® METEON®

UNI COLOURS



FINISH

SATIN

FIXING SYSTEM

TS1.50 VISIBLE (EXPOSED) FIXING WITH SCREWS ON A TIMBER SUBFRAME

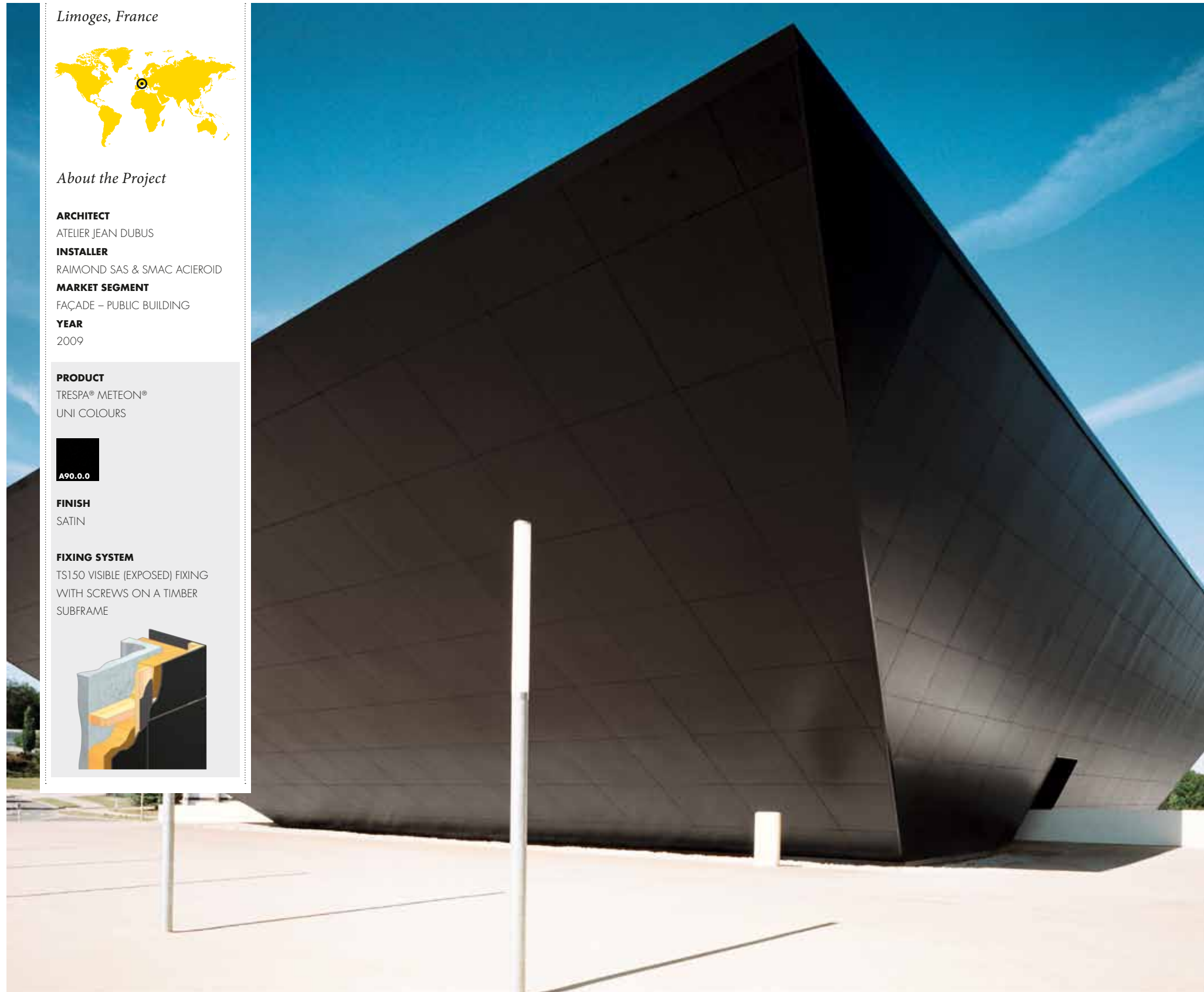
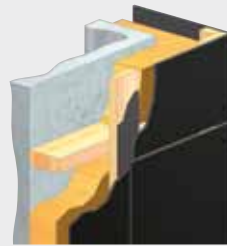

NEW UNI COLOUR
A11.8.0
CERAMIC GREIGE



NEW UNI COLOUR
A24.0.3
POLAR BLUE



BOLD, GUTSY AND VIBRANT

TEXT RIYA PATEL
PHOTOGRAPHY THEA VAN DEN HEUVEL/DAPH & JAMES WINSPEAR

STUDENT ACCOMMODATION MAKES A MODERN
DESIGN STATEMENT IN A BRITISH SEASIDE RESORT.



Project architect:
Jess Paull
Stephen Marshall Architects

Installer:
Evgeny Korchevtsev
D-Mitro Construction

Supplier:
Michael Brookman
Vivalda

GONE ARE THE DAYS OF STUDENT ACCOMMODATION HOUSED IN DREARY CONCRETE OR BRICK BUILDINGS ON THE PERIPHERIES OF BRITAIN'S TOWN CENTRES. TODAY'S HALLS OF RESIDENCE ARE INTEGRAL PARTS OF THE URBAN FABRIC, REALISING A DEMAND FROM STUDENTS WHO WANT TO ENJOY CENTRAL LOCATIONS WITH EASY ACCESS TO SHOPS, RESTAURANTS AND NIGHTLIFE AS WELL AS THE UNIVERSITY CAMPUS. ▶



"There were more details on these clocks than there were on the entire building!"

Stephen Marshall Architects' University Square development for the University of Essex is just that – a bold, colourful intervention in the seafront town of Southend that revives its vibrancy and brings a new perspective to the typology of student housing.

HOW IT ALL STARTED

The client, Hollybrook Homes, bought the prominent site in central Southend from the former South East Essex College, and handed it over to the University of Essex once the accommodation was completed in 2010. "It actually started life as a residential scheme for Hollybrook," explains lead architect Jess Paull, "That's what we got planning permission for. And then it was turned into this scheme, which basically took the residential footprint and reduced the size to suit student accommodation".

The site is on a large area of wasteland used as a car park since the college's buildings were demolished some time ago. It sits between Southend's two major railway stations and can be seen from the busy high street. Paull describes it as a buffer zone between commercial and residential parts of the town.



"There is a method to the madness; it's not completely arbitrary". Jess Paull

"We tried to resolve the scale issue of going from two-storey residential to four/five-storey commercial," he says, "and we wanted to make the highest part a focal point for the high street".

In total, the blocks contain 561 student rooms in cluster flats and 64 self-contained studios, situated over a 300-space car park. By incorporating the basement car park, which was a requirement of the local council, a landscaped podium was created in the centre of the site which all the buildings look into. Like a modern college quadrangle, the podium forms the platform of entry to the various accommodation blocks, a feature that also makes access to the student housing more secure.

STACKED TETRIS SHAPES BY THE SEA

To bring some uniformity to the blocks of varying height, it was decided to treat the exterior design as a "fabric". "Student housing can be quite dull," says Paull. "It's just a series of rooms with windows. So the trick to try and make it look not institutional was to just throw a fabric over it, which, whatever you did to it, would suit the different sizes of buildings".

The exterior pattern is a series of large brightly coloured rectangles, each with a pair of windows at the centre. "There is a method to the madness; it's not completely arbitrary," says Paull, whose tessellated cladding design has been compared both to Lego bricks and a stacked set of Tetris shapes. "But on the whole, the idea is that the thing just snakes around, going from landscape to portrait".

The only prominent interruption to the snaking pattern is a set of three clocks on



"The façade was installed in less than eight months". Evgeny Korchevtsev

top of the College Way elevation's 10-storey tower. The clocks – one for the hour, one for the minute, and one for the second – function as a fun addition to the project, enforcing the building's sense of civic purpose and acting as a focal point when seen from Victoria Plaza, Southend's main public space. The clocks are also a talking point for the locals. "People do struggle with what it means," says Paull. "They see the seconds clock and they say 'oh that's going round fast! It takes only a minute for the hand to go around!' And then they realise," he adds with a smile.

REALISING THE PATTERN

The repetitive nature of the cladding design was achieved in sections of Trespa® Meteor® fixed using a TS700 fixing system on pre-cast concrete panels. This made the concept fairly easy for sub-contractor D-Mitro Construction Ltd to carry through to realisation. Evgeny Korchevtsev, who ran the project for D-Mitro, says: "We came across lots of issues on site. But when we saw the size of the project, we thought it would be much more difficult than it ended up being. We had not 20, but just below 200 details on this project, bearing in mind the flashings, copings and everything else. All the bits and pieces".

Trespa® Meteor® panels were specified after Stephen Marshall Architects did an exercise on sheet sizes for the client aimed at reducing material wastage. Paull says: "We've used a few of these panels before, and we've always felt Trespa® is the high end of the range. Strangely, Trespa is the only company that do a sheet

of a specific size. And Trespa's jumbo sheet seemed to work really well in terms of the minimum amount of wastage. A few of the competitors don't do a sheet quite as big, so you end up throwing a quarter of it away".

Michael Brookman from Vivalda Ltd, the company that supplied the Trespa® panels for the development, concurs: "Trespa® isn't the cheapest when you look at the square metre price. But on site, it far outweighs the competitors. Because of the variation of the

four sheet sizes, it's much more flexible, with the cost benefit of not wasting too much material".

An off-site mock-up was made to help the team fine-tune details of how the panels should come together, whether overlapped or with mitred edges. "It's a very simple system, but it does throw up some tricky issues which need to be resolved," says Paull. Another area that needed greater attention than just a tweak to the standard detail was the triangular shaped entrance to the student offices, common-room and laundry, at the point of access facing Napier Avenue. Both here and on the three clocks, a steel structure had to be introduced in place of the precast concrete panels. "There were more details on these clocks than there were on the entire building!" says Korchevtsev.

"It was very difficult to do," agrees Paull. "Because [the clocks] were held off the building a long way, you couldn't do a traditional rainscreen bracket behind them. Plus it's a coastal location, and so it's windy, so the steel frame ended up being enormous. It was also very complicated, working at height, 10 storeys up in the air".

THE REASON BEHIND THE COLOURS

Four main colours are used on the façades of the student accommodation: blue, yellow, red and green. Stephen Marshall Architects' rationale for this design is that the red panels reflect the redbrick Victorian terraces along Queens Road; those facing into the landscaped podium are green; the yellow on the main ▶

Southend on Sea, UK



About the Project

- PRINCIPAL/MAIN CONTRACTOR**
HOLLYBROOK
- DISTRIBUTOR**
VIVALDA
- INSTALLER/SUBCONTRACTOR**
D-MITRO CONSTRUCTION LTD.
- ARCHITECT**
STEPHEN MARSHALL ARCHITECTS
- YEAR**
2010
- MARKET SEGMENT**
MULTI HOUSING/APARTMENTS

PRODUCT
TRESPA® METEON®
UNI COLOURS



3 PROJECT COLOURS



FINISH
SATIN

FIXING SYSTEM
TS700 VISIBLE (EXPOSED) FIXING WITH RIVETS ON A METAL SUBFRAME

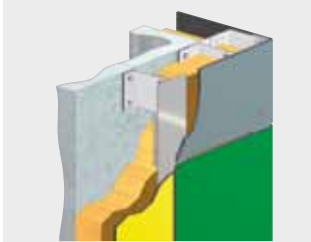



with D-Mitro's guys quite carefully with scheduling, but with Trespa you always know that the lead time quoted is what you're going to get. When you're talking about a project of that size, you need to be absolutely sure when the material is coming in".

Apart from specifying the Trespa® panels for performance reasons, Brookman says architects commonly choose the rainscreen cladding product for its qualities in vandal resistance, impact strength, life expectancy, BBA certification and weatherproofing. For Paull, there was another advantage to using Trespa® for this job. The window reveals of the student accommodation blocks are all designed to be black, to give emphasis to the geometry and colour of the various panels. Paull says: "The best thing about the Trespa® is that a black panel on the face looks pretty much the same as the cut edge of a panel in any colour. Since Trespa's boards are black all the way through, we didn't have to worry about seeing a weird colour on the edge or introducing a trim or something. That would just overcomplicate things".

elevations nods to Southend's beaches, and the blue panels to the west of the site are intended to merge with the colour of the sky. Grey and white panels break up the sections of bold primary colours.



"You always know the lead time quoted is what you're going to get". *Michael Brookman*

Getting the colours exactly right meant choosing from the RAL chart, rather than Trespa's standard colour list, a move that Korchevtsev says lengthened the process of getting the cladding up on site. He says: "Even though there was a lot of repetition and just seven colours, we had to deal with more. And because we had several thousands of panels for this job, it made the scheduling difficult".

Brookman says that establishing realistic lead times with Trespa International BV, situated in The Netherlands, where the panels are fabricated, was key to the project running smoothly. "[Southend] is the biggest job I've been involved with, and was complicated by using special colours. We had to coordinate

just one and a half years," says Korchevtsev, "The façade was installed in less than eight months. Considering the scale of the job, I think it's the quickest one I've ever done". Paull puts the speed of construction down to the precast concrete panel system. "Precast systems really help because they go up so fast. It's like building a house of cards. There's no frame, it's just walls and floors stacked up on top of each other. I've never worked on a job that went so quick. It went from wasteland car park to a three-storey basement in a matter of no time".

THE NEED FOR A BOLD BUILDING

Stephen Marshall Architects' development at Southend is undeniably bold in its visual

language and approach to resolving the townscape issues of the site. The vibrant use of cladding is an assertive move, which sets the development apart from the existing fabric of the town and gives its variously sized buildings focus as a regenerative quarter. But on a large site, and for such a great swath of the Southend map, has the strategy been too bold? "You either love it or you hate it," says Paull. "But it needed to be quite a bold building to do what we wanted it to do. The rest of the urban fabric around there is quite run-down. It needed something quite vibrant to mark itself on the map, and because it's a little bit away from the high street and the plaza, it needed something to say: 'Here I am'".

The student housing market in Britain is facing an uncertain time. With funding cuts to higher education, more investments in improving or providing new student accommodation are being shouldered by the private sector. GVA, an adviser on the student housing market, predicted in its summer 2011 review that university and private sector partnerships like that between the University of Essex and Hollybrook Homes will be more common in the future, and that students paying increased tuition fees are on the hunt for the type of well-designed, contemporary, centrally located student accommodation

that such a project provides. The report concluded: "Post 2012, the majority of new undergraduate students will be paying £27,000 for a degree course in fees alone. In our opinion, if committing to that level of expenditure, they will expect a better quality of residential accommodation. With university stock generally of a lower quality, we would expect both that the private sector will see sustained growth in demand for its product, and universities will face increasing pressure to improve their ageing stock".

The pressure from wholly privately built and owned student housing projects, which are increasingly appearing all over Britain's university towns, has introduced a competitive attitude to university-owned purpose-built student accommodation; and the effect is shifting the typology towards an ever more daring architecture.



A TREND IN STUDENT ACCOMODATION

It seems that also abroad there's a trend for associating bright colours and bold patterns with this particular building use. Architectenbureau Marlies Rohmer's award-winning Smarties building in De Uithof, The Netherlands, presented itself as a pixelated mass of brightly-coloured aluminium panels in orange, green, red, white and black. The practice poetically describes the project as, "a colourful hive for young eggheads" with "a lively façade [that] reflects the wide diversity of tenants from all corners of the world".

Paull says it's possible that there's a trend emerging along these lines. "But it really depends where you are. If you're doing it in Oxford or Cambridge, you're not going to make it in bright colours. It depends on the location. Around London, you can challenge the surroundings a lot more. For this particular site, for this particular purpose, it worked very well".

Unlike the Netherlands, perhaps the British public are less amenable to modern design statements like University Square turning up on their doorstep. Brookman is most plain-faced about how the colourful Southend student accommodation project has been

received by the local community.

"People have told me it's a monstrosity. It massively stands out. And people have taken views because there's Victorian houses around there, and it's such a bold statement," he says, "but it really has brought vibrancy to this part of Southend".

The architecture may not suit all tastes, but the development is ultimately successful at repairing a forgotten piece of Southend's urban fabric in a way that responds to both the local context and the needs of an increasingly demanding student market. University Square is one clear vision of how student housing should be built in the UK. Given the dramatic changes in funding to higher education that will shape the student housing sector over the coming years, it will be interesting to see how many more projects will share its gutsy approach. ■



Please note that the views and opinions expressed in this article are those of the authors and do not necessarily reflect the official policy or position of Trespa International B.V.

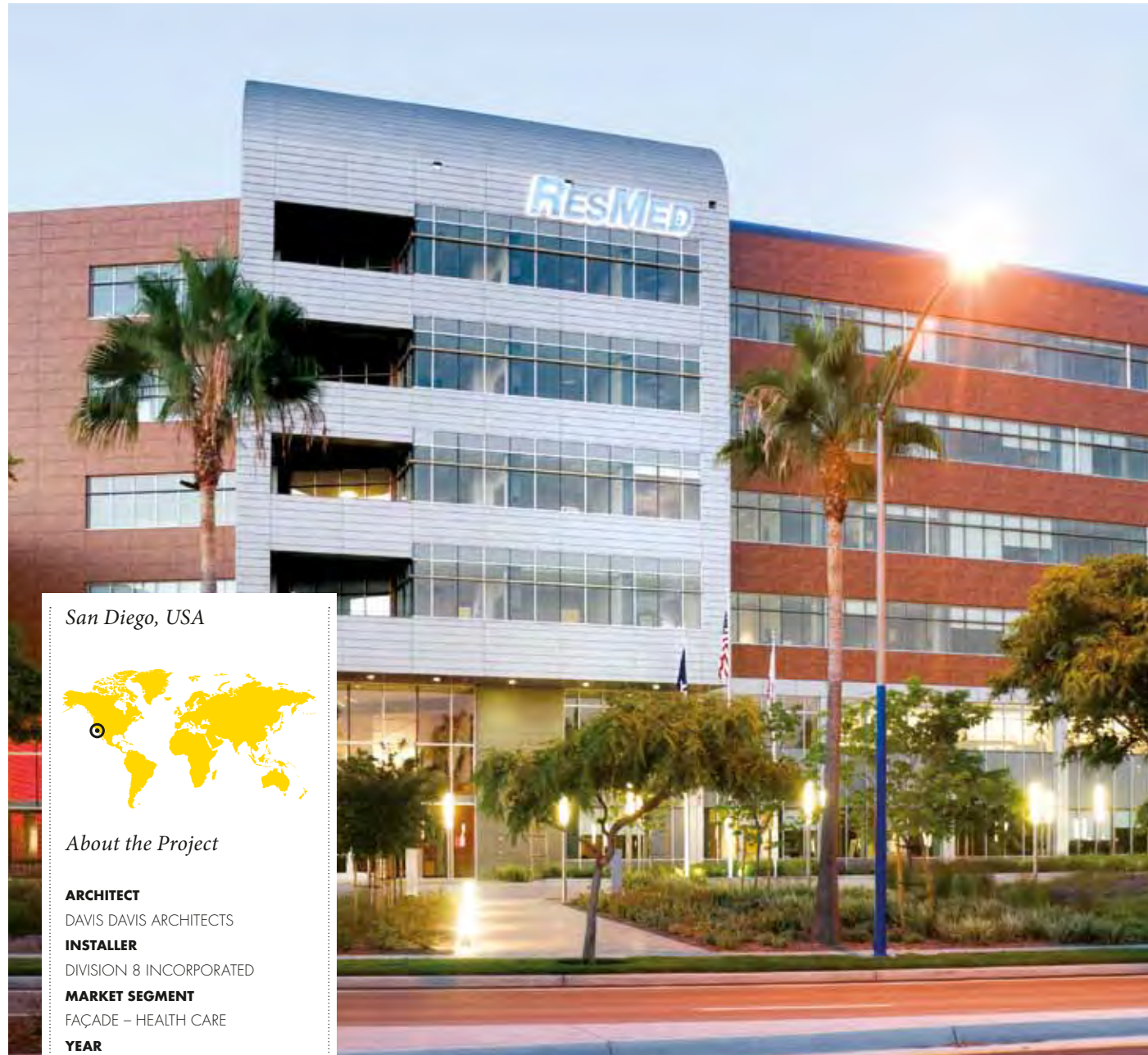

San Diego, USA



About the Project

ARCHITECT
DAVIS DAVIS ARCHITECTS
INSTALLER
DIVISION 8 INCORPORATED
MARKET SEGMENT
FAÇADE – HEALTH CARE
YEAR
2008

PRODUCT
TRESPA® METEON®
NATURALS



FINISH
SATIN

FIXING SYSTEM
TS110 VISIBLE (EXPOSED) FIXING
WITH SCREWS ON AN ALUMINIUM
SUBFRAME

RESMED LABORATORIES

A BREATH OF FRESH AIR

LOCATED IN THE USA, THIS HEADQUARTERS WAS COMMISSIONED BY A COMPANY THAT DEVELOPS MEDICAL PRODUCTS FOR THE TREATMENT OF RESPIRATORY DISORDERS. THE BUILDING SYMBOLISES ITS WORK BY UTILISING THE LATEST BUILDING TECHNOLOGIES TO CREATE A HEALTHY AND SUSTAINABLE BUILDING. A VENTILATED FAÇADE ALLOWS THIS BUILDING "TO BREATHE". OTHER INNOVATIVE TECHNOLOGIES INTEGRATED INTO THE BUILDING INCLUDE LIGHT SHELVES THAT BOUNCE LIGHT DEEPER INTO THE ROOMS AND AN UNDERFLOOR AIR DISTRIBUTION CENTER.

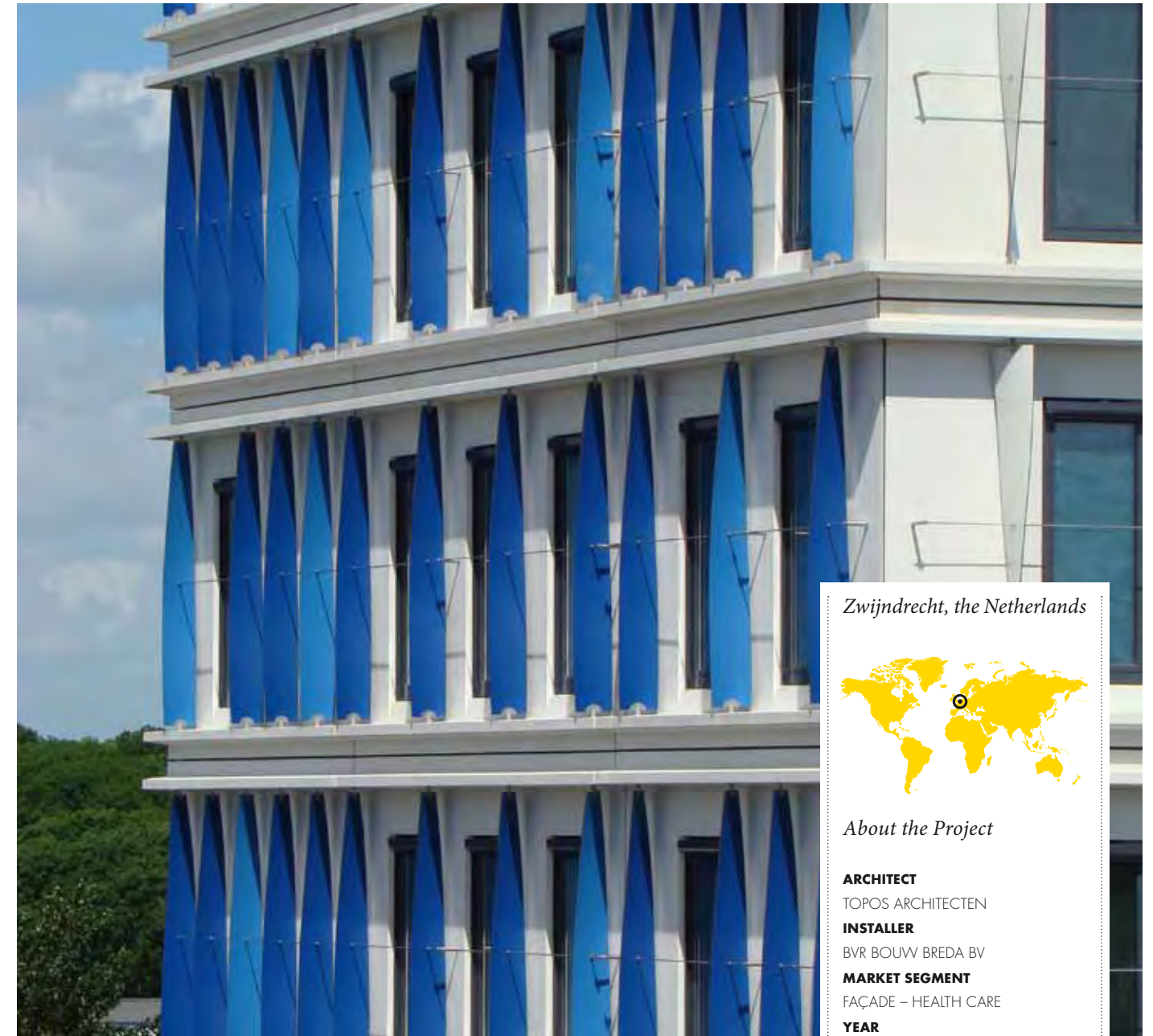

Zwijndrecht, the Netherlands



About the Project

ARCHITECT
TOPOS ARCHITECTEN
INSTALLER
BVR BOUW BREDA BV
MARKET SEGMENT
FAÇADE – HEALTH CARE
YEAR
2011

PRODUCT
TRESPA® METEON®
UNI COLOURS

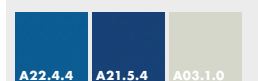

FINISH
SATIN

FIXING SYSTEM
NON STANDARD

REHABILITATION CENTRE ZWIJNDRECHT

TWISTED SIDES

RISING HIGH ABOVE AN ADJACENT HIGHWAY, THE COLOUR OF THIS 'CARE HOTEL' SWITCHES FROM BLUE TO WHITE AS DRIVERS PASS BY. DOUBLE-SIDED PANELS, WITH ONE SIDE WHITE, THE OTHER BLUE, WERE TWISTED BY 90 DEGREES TO CREATE A HELIX SHAPE. THEY WERE THEN INTEGRATED INTO THE PROJECTING EDGE OF THE PRECAST CONCRETE FAÇADE. PREFABRICATED SANDWICH WALL ELEMENTS WERE LIFTED BY CRANE AND INSTALLED ON-SITE, ALLOWING THE STRUCTURE OF THIS 10-STORY BUILDING TO BE COMPLETED IN JUST 11 WEEKS.

TEXT MARK STUDHOLME PHOTOGRAPHY JELMER DE HAAS

THE IDEAS FACTORY AND ITS INNOVATIONS

MARCELLE HODGSON LEADS THE INTERNATIONAL GROUP OF SCIENTISTS AND RESEARCHERS THAT MAKE UP THE INNOVATION TEAM AT TRESPA. AS ONE OF THE THREE DEPARTMENTS WITHIN THE RESEARCH AND DEVELOPMENT DEPARTMENT THEIR ROLE IS TO DEVELOP AND REALISE NEW PRODUCTS AND IDEAS. SHE TELLS US WHAT IT IS LIKE TO WORK FOR TRESPA'S INNOVATION TEAM AND WHAT THE FUTURE HOLDS FOR FAÇADES.

Originally from South Africa, Marcelle was introduced to Trespa while studying at the University of Technology in Eindhoven. That was 11 years ago and since then she has led the development of many of Trespa's leading innovations. She tells us what it is like to work for Trespa's Innovation Team and what the future holds for façades.

HOW IMPORTANT IS RESEARCH AND DEVELOPMENT TO TRESPA?

The entrepreneurial spirit and daringness by the management in the past to take big steps has got us to where we are today. It comes straight from the management that Trespa has to be at the forefront. The reason why I have been at Trespa for more than 10 years is because of this importance placed upon innovation.

HOW DOES THE TEAM CONTRIBUTE TOWARDS THIS INNOVATION?

We have a nice spread of people in the team who all have their own unique energy and enthusiasm. There are

scientists, but we also have one electrical engineer. Everyone is open, motivated and pro-active.

IF A MEMBER OF YOUR TEAM WAKES UP IN THE MIDDLE OF THE NIGHT WITH AN IDEA, DO THEY HAVE THE OPPORTUNITY TO PUT IT FORWARD?

We encourage our members to bring ideas forward and there is definitely room for ideas, whether it comes from my team or someone else at Trespa. As I mentioned before it comes straight from the management and down that Trespa has this drive and passion to be at the forefront of the industry. This can only be done by innovating and realising ideas.

HOW DOES THIS PROCESS WORK?

We like to have ideas coming from the technical side and the market side. If it's a good idea you are given time to form a case, this is then presented to management, from there they will decide if it's worth a feasibility study. The management is very selective with the ideas they wish to advance. This is because of the amount of time spent

on not only realising the idea but also to perform a thorough series of tests to make sure that the product has the same high-end qualities as the rest of Trespa's products on the

market. This to ensure it will perform for many years to come and deliver the quality expected from Trespa. A stage gate process is used to manage this development process. We are currently developing a more structured system to help foster and select initial ideas.

WHAT ARE YOU CURRENTLY WORKING ON IN THE INNOVATION TEAM?

We are further improving the look and feel of Trespa® Meteon®. Currently there are Gloss, Rock and Satin finishes to the panel. In response to the market trend towards more authentic materials we are developing a

“It is an ethos of the innovation team to challenge existing ideas”.

relatively new people who bring fresh ideas and life into the team; then we also have lots of experience, including someone who has worked at Trespa for more than 25 years. The blend of experience and new enthusiasm allows us to challenge existing ideas in the right way. It is an ethos of the innovation team to challenge existing ideas.

WHAT KIND OF PEOPLE WORK IN THE INNOVATION TEAM?

It is a very international environment. We currently have Dutch, South African, Belgian, Portuguese and Greek. They are mostly chemical engineers and material



matt finish in combination with some of our decors. The aim is to emulate the sort of matt look that wood or concrete has. We believe that this will enable the architect to create façades with improved authenticity while maintaining the advantages of Trespa® Meteon®. In addition to this we are excited about a new development that has just been finalised, and is now available on the market (only available for selected countries). This solution is the possibility to have project patterns and decors printed onto a Trespa® Meteon® panel. What makes our solution particularly special is that the longevity of the pattern and colours is guaranteed. The designer can think of just about any pattern or decor they wish and we can supply them with it printed on Trespa® Meteon®. Soon we will also be able to offer a 10-years product guarantee for the Naturals & Wood Decors in places with extreme climate conditions like Florida and we are becoming more and more involved in the field of sustainability.

WHAT DO YOU THINK TRESPA IS LEADING IN?

Longevity is one of our strengths. We give the architects the opportunity to put their signature on a building and it still looks great after 10 years. An architect's signature

“We are developing a matt finish to create façades with improved authenticity”.

on a building could be a specific colour for example. If they provide us with a colour sample most of the time we can match that sample and create a Trespa® cladding for them that will stand the test of time.

WHAT ARE THE LONG-TERM OBJECTIVES OF THE INNOVATION TEAM?

We're looking to address the demand for sustainable products and solutions. Previously the team focused mainly on design issues, now we develop both design and sustainable solutions. We believe that Trespa can provide and develop sustainable solutions. Ventilated façades are a solution that we are promoting; these can help reduce energy use in a building. In our production processes we also aim to use raw materials which help improve the total impact on the environment, such as use of woodchips instead of paper and use of waste streams from other industries as valuable raw materials. ■

NEW UNI COLOUR

**A06.7.1
NATURAL GREIGE**

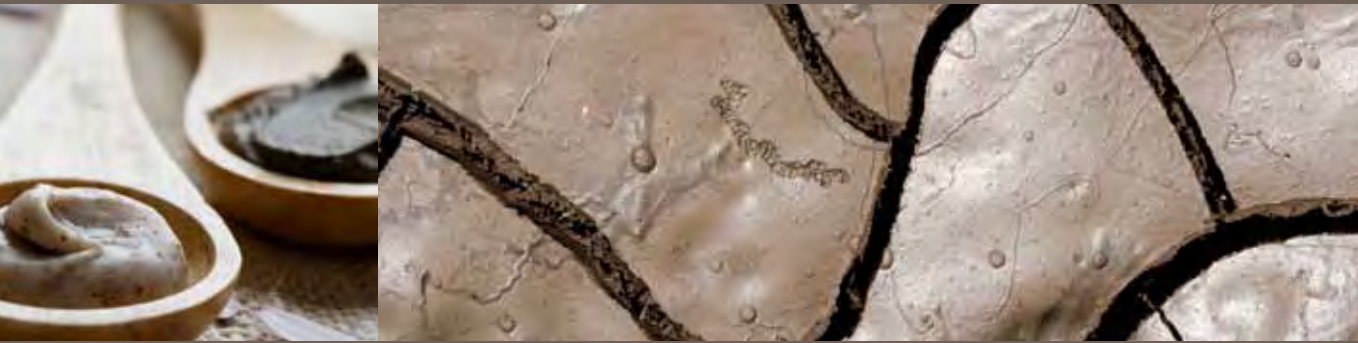

NEW UNI COLOUR

**A41.0.6
MOJITO GREEN**



SUSTAINABILITY AND TRESPA

LONG BEFORE THERE WERE EUROPEAN REGULATIONS REQUIRING COMPANIES TO ASSESS THEIR ENVIRONMENTAL IMPACT, TRESPA WAS ALREADY DOING SO UNDER THEIR OWN INITIATIVE. AT THAT TIME, DUE TO THE EMERGING AWARENESS AND THEREFORE PREMATURE ASSESSMENT METHODS OF ENVIRONMENTAL CONCERNS, THERE WAS NO PRIMARY SINGLE HOLISTIC ASSESSMENT METHOD. CONSEQUENTLY RESULTS BETWEEN METHODS WERE DIFFICULT TO COMPARE AND GAVE LITTLE QUANTITATIVE DATA.



Then in 1994 Trespa commissioned its first Life-Cycle Assessment (LCA) of Trespa® Meteon®. At the time LCAs were relatively unknown. One of the first books on LCAs titled LCA Sourcebook was first published in 1993. In commissioning this LCA in 1994 Trespa was one of the first companies in the industry to use what is still considered the most scientific, comprehensive and fact-based tool to measure environmental impact.

The results from the 1994 LCA were used to analyse a new development within Trespa that made it possible to substitute Kraft paper, a core Trespa® Meteon® ingredient, with woodchips for a big part of our product portfolio. Through this substitution the processes required to produce Kraft paper were partly avoided, minimising the

environmental impact of Trespa® Meteon®. Sustainability is one of Trespa's License to Operate priorities. These are the responsibility of top management, but also require the commitment of the employees, and come first in the company's strategy. For a long time Trespa has been fully committed to playing its part in understanding and meeting the associated diverse challenges, now and in the future.

THE POLICY

The basis of Trespa's sustainability policy is a strong belief that any change should start with the company itself. Trespa's approach to sustainable development is framed by three basic principles:

1. DO NO HARM

Trespa's first task is to comply with the safety, product and sustainability rules and guidelines set by the countries that it operates in. In addition, Trespa is looking for opportunities to minimise the impact of its operations and products.

2. DO GOOD

The second element of Trespa's policy is that it strives to help its customers realise their sustainability challenges. This means that Trespa looks for opportunities to maximise the sustainability contribution of its products in their end-use, for example façade cladding. Moreover, Trespa will continue to look for opportunities and initiatives to support and promote longer term sustainable development beyond the direct scope of its current operations.

3. DO BETTER

Finally, Trespa believes new business opportunities will arise from sustainable development. Many sustainability challenges also constitute opportunities that make good business sense today and will allow the company to continue to grow its business.

LIFE-CYCLE ASSESSMENT 2011

The most recent LCA commissioned by Trespa was in 2011. This assessment looked at the whole life cycle impact, from Cradle to Gate, of a 1m² cut of Trespa® Meteon®. The results of this assessment are used to create initiatives related to the Sustainability Policy. ▶

THE SUSTAINABILITY TEAM

CURRENTLY TRESPA IS FOCUSING ON IMPLEMENTING THE FIRST SUSTAINABILITY POLICY 'DO NO HARM'. THIS IS UNDERTAKEN BY A SUSTAINABILITY TEAM AT TRESPA.

THIS YEAR THE TEAM SET THEMSELVES THE TARGET OF REDUCING TRESPA ENERGY USE BY 3% AND TO GENERATE 10% LESS WASTE THAN THE PREVIOUS YEAR.

THROUGH MONTHLY REVIEWS OF TRESPA'S PROCESSES A NUMBER OF INITIATIVES HAVE ALREADY BEEN INTRODUCED.

EXTRACTION OF RESOURCES

A NUMBER OF RAW MATERIALS AND PROCESSED MATERIALS ARE USED TO CREATE TRESPA® METEON®.

THE UPSTREAM SUPPLY CHAIN AND THEREFORE THE PRODUCTION OF THE MATERIALS THAT TRESPA PURCHASES ARE ALL ASSESSED.

IT WAS FOUND THAT THE UPSTREAM SUPPLY CHAIN IS THE MAIN SOURCE OF MOST ENVIRONMENTAL IMPACTS.

UPSTREAM CONTRIBUTIONS FROM RAW MATERIAL PRODUCTION AND TRANSPORT ARE A FOCAL POINT FOR TRESPA'S SUSTAINABILITY EFFORTS.

CRADLE

THE PRODUCTION OF MATERIALS FROM THE RESOURCES

ONCE ALL THE RAW MATERIALS ARRIVE AT TRESPA, PROCESSES SUCH AS CREATING THE RESINS ARE NEEDED TO CREATE THE FINISHED PRODUCT.

EACH PRODUCTION PROCESS ON THE TRESPA SITE, INCLUDING TRANSPORT, IS ASSESSED.

TRESPA CAN INFLUENCE THIS PHASE OF THE CYCLE THE MOST.

ON-SITE EMISSIONS FROM RESIN PRODUCTION AND IMPREGNATION IS A FOCAL POINT OF TRESPA SUSTAINABILITY EFFORTS - IN ADDITION TO A REDUCTION IN PRIMARY ENERGY USE FOR TRESPA'S OWN PRODUCTION PROCESSES.

GATE

THE USE OF THE PRODUCT

THE FINISHED PRODUCT IS TRANSPORTED, ON AVERAGE 600KM, TO THE SITE WHERE IT WILL BE USED.

THE AVERAGE LIFETIME ONCE INSTALLED FOR TRESPA® METEON® IS ASSUMED TO BE 50 YEARS.

IT WAS FOUND THAT THE UPSTREAM SUPPLY CHAIN IS THE MAIN SOURCE OF MOST ENVIRONMENTAL IMPACTS.

DUE TO THE CARBON CONTENT OF TRESPA® METEON®, CARBON IS CAPTURED FOR UPTO 50 YEARS OR LONGER WITHIN THE PANEL-OFF SETTING SOME OF THE EMISSIONS CREATED IN ITS PRODUCTION.

THE END OF LIFE

WHEN TRESPA® METEON® IS DEMOLISHED IT IS ASSUMED THAT 50% OF THE PRODUCT AT THE END OF ITS LIFE IS INCINERATED IN AN AVERAGE EUROPEAN WASTE INCINERATION PLANT WITH ENERGY RECOVERY. THE REMAINING 50% IS TAKEN TO A LANDFILL SITE.

WITH THIS SCENARIO THE ENERGY STORED WITHIN THE PANEL IS RECOVERED, OR THE CARBON CAPTURED BY THE RAW MATERIALS WILL CONTINUE HOLDING THIS CARBON IN LAND FILL. 75 M² OF 8MM PANELS CAPTURES 1 TONNE OF CO₂.

GRAVE





ONE OF TRESPA'S RECENT INNOVATIONS IS ITS NEW PRODUCT PACKAGING. THE CHANGE IS A RESULT OF STUDIES CARRIED OUT BY TRESPA OVER THE LAST TWO YEARS TO FIND A HIGH QUALITY, UNIFORM, SUSTAINABLE, GLOBALLY COMPATIBLE WAY OF PACKAGING TRESPA® PANELS.

UNIFORM, GLOBALLY COMPATIBLE WAY OF PACKAGING TRESPA® PANELS

One standard way of packaging with polypropylene coversheets inside foil

IMPROVEMENT IN THE QUALITY DURING STORAGE

The cardboard currently used and the Trespa® coversheets will be replaced by polypropylene coversheets to reduce warping of Trespa® panels during transportation and storage.

These sheets will protect Trespa® products better against moisture and mechanical impact.

SUSTAINABLE SOLUTION

They are made of 50% recycled and 50% virgin material and are lighter compared to current packaging materials. The sheets can be reused for repackaging.



NEW RECOGNISABLE YELLOW FOIL

In order to make the Trespa® panels more recognisable in your warehouse and on building sites the current transparent foil will be replaced by yellow foil.

Trespa® selected an environmentally friendly pigment and uses the lowest possible concentration of this pigment to colour the foil.

NEW PALLET LEAFLET

Design and installation recommendation

Transport, handling and storage



LED LIGHTING

Some 8000 fluorescent tubes in the whole production facility in Weert, The Netherlands will be replaced with LED lighting. This initiative is expected to achieve a 40-60% reduction in energy use. Once thought of as energy efficient, when compared with incandescent lighting, fluorescent tubes have been overtaken by LED tubing when energy efficiency, cost and lifespan are all taken into account.

PEFC WOOD

Since obtaining a PEFC Chain of Custody certification in 2009 Trespa has been able to offer PEFC certified products into the market. This certification was possible because

Trespa is able to demonstrate both its understanding and adherence to sourcing and supply chain standards outlined by PEFC.

Trespa first released a PEFC version of its popular TopLab® products for laboratories, called Trespa® TopLab ^{ECO FIBRE}®. For these products, Trespa sources raw material in the form of PEFC certified woodchips. Now PEFC product certification is also available for a select range of Trespa® Meteon® products*.

THE FUTURE

Environmental Product Declarations (EPD), are becoming more and more common in the construction industry. The overall goal of an EPD is to provide relevant, verified and comparable information about the environmental impact from products.

Building rating systems such as BREEAM (UK), FDES (France) and DGNB (Germany) are using EPD's to rate the environmental impact of projects. The trend is that many more systems will start including EPD's in their ratings.

By using the data collected from the 2011 LCA Trespa is currently having its EPD verified.

With a verified EPD clients of Trespa can easily submit these data for building environmental ratings.

Due to new sustainable initiatives being implemented and the achieved progress in energy savings and waste reduction by the sustainability team, every year a new LCA is required to review the new initiatives and the mitigated impacts. This ensures that Trespa is always improving upon its sustainability. ■



* NOTE The PEFC certified product offer may vary. For full details on product range and pricing please contact your local sales representative.

“Safety in general
has become an
important issue”.

Paul Vandeveld

TEXT CATHELIJNE NUJSINK
PHOTOGRAPHY JELMER DE HAAS

HOW FIRE BEHAVES

About Professor Paul Vandeveld

- **1967**
DEGREE IN MECHANICAL AND ELECTRICAL ENGINEERING
- **1975**
DOCTORATE IN STUDY OF THE PHENOMENON OF IGNITION MATERIALS – PROPOSAL FOR NEW MEASUREMENT AND ASSESSMENT
- **1975 – CIRCA 1995**
WORKED FOR THE EUROPEAN COMMISSION SUPPORTING STUDIES IN THE FIELD OF FIRE SAFETY AND HARMONISING EUROPE'S PRODUCT INDUSTRY
- **1982**
CO-AUTHOR *STRUCTURAL FIRE, PART I AND PART II*
- **CIRCA 1985**
CO-FOUNDER AND PRESIDENT EGOLF
- **2000**
CO-AUTHOR *FIRE SAFETY IN BUILDINGS – PART 1 PASSIVE PROTECTION*
- **2005**
DIRECTOR OF WFRGENT NV.
- **2011**
FIREFORUM 'LIFE TIME ACHIEVEMENT' AWARD FOR PAVING THE WAY FOR A TRULY SCIENTIFIC STUDY OF FIRE SAFETY ENGINEERING
- MEMBER OF VARIOUS NATIONAL COMMITTEES AND WORKING GROUPS RELATED TO FIRE SAFETY

THROUGHOUT HISTORY, FIRE HAS BEEN AN ESSENTIAL SOURCE OF HEAT, LIGHT AND EVEN, IN THE FORM OF BONFIRES, JOY AND FESTIVITY. BUT WHEN IT STARTS TO SPREAD UNCONTROLLABLY, JOY TURNS TO FEAR. PROFESSOR PAUL VANDEVELDE HAS SPENT HIS ENTIRE CAREER STUDYING THE BEHAVIOUR OF FIRE IN BUILDINGS. THANKS TO HIS CONTRIBUTION TO THE DEVELOPMENT OF THE SINGLE BURNING ITEM TEST, BUILDING MATERIALS IN EUROPE ARE NOW REGULATED TO IMPROVE FIRE SAFETY AND CONSEQUENTLY BETTER PROTECT OCCUPANTS.

WHAT MADE YOU SO INTERESTED IN FIRE? WAS BECOMING A FIRE EXPERT THE FULFILMENT OF A CHILDHOOD DREAM?

Actually, I accidentally became fascinated with fire. While writing my master thesis during my last year at Ghent University, my supervising professor showed interest in starting a test-laboratory on the fire behaviour of building materials. This interest in testing materials on fire safety was a direct consequence of the big fire that happened in the Innovation Department Store in Brussels in 1967, killing over 250 people. The professor needed people to start his laboratory and that is how I got involved in this business. I must admit that initially I saw it as a temporary job until I found a "real" job. But once you get into fire, you never get out!

WHY DID YOU FIND THE NEED TO MAKE SCIENTIFIC RESEARCH OUT OF THIS?

Fires in buildings started to happen much more frequently at that time due to habit changes. Think of increasing fire loads, the growing use of electrical equipment and the wish for more comfort, but also because of the production and use of new materials such as plastics. As a consequence of the big fire accident in Brussels and many others in the late 1960s, finally some fire regulations were set up in Belgium. Fire was at that time therefore still a relatively young science, which is an attractive point for young scientists.

WHAT TYPES OF FIRE CAN WE DISTINGUISH?

In Europe we use the European Standard Classification of Fires, which identifies fires according to different classes. Class A fires, for example, occur when solid organic materials such as timber or textiles are heated to their ignition point. The material stays solid when heated. Class B fires are fires that don't burn in a solid stage but turn into liquid when heated. When you take a look at a fire extinguisher, you will see an indication, showing if it is suitable for Class A fire or Class B fire, or both. When the classification on the label doesn't correspond with the actual type of fire, the fire extinguisher may still work but is certainly less efficient. But regardless of the label, grab the fire extinguisher when a fire breaks out.

WHAT IF THE FIRE EXTINGUISHER ISN'T EFFICIENT ENOUGH? HOW DOES A FIRE DEVELOP IN A BUILDING?

When talking about building fires we make a distinction in the evolution of fires: the pre-flashover, the flashover and the post-flashover phase. The pre-flashover refers to the initial development of a fire. In this phase, the materials inside the room define how fast the fire will develop. If you have a lot of combustibles, that is to say easily ignitable material, the fire will develop quickly. If the building materials do not give off a lot of heat, the process until the fire develops into a fully developed phase will go much slower.



Pressure gauge



Probes connecting the measuring equipment

After the start of the fire, the temperature goes up to 200-300 °C. In this stage of the fire, all organic products start to decompose and give off combustible gases. As soon as the windows break and extra air comes into the room, the gas-air mixture will ignite. This is what is called a flashover.

HOW DOES THE FIRE BEHAVE FROM THIS STAGE?

After the flashover you have a totally different situation. The temperature quickly rises and then stays approximately constant above 700-800 °C. From now on, it is the total amount of combustible material in the room that is important, and not so much the behaviour of individual products, because the total amount determines how long a fire can last. The room on fire, or the fire compartment, should at all times remain closed and separated from neighbouring compartments. For this aspect, we determine the fire resistance of the separating elements and the loadbearing structure. If the



structural elements fail, the building will come down. Once a flashover happens, the risk is too big for the fire brigade and they know they can no longer enter the burning compartment or even the building. They will have to extinguish the fire from outside.

HOW EFFICIENT ARE COMPARTMENTS IN LIMITING THE SPREAD OF FIRE THROUGH A BUILDING?

Fire easily moves through the corridors of a building, and in this way spreads over long distances. Compartments have to ensure that the entire building doesn't catch fire, so that the fire brigade can still attack from the inside. A compartment is a larger part of the building, usually one floor, with a size up to 2500 m². A compartment can also contain sub-compartments.

Sub-compartments don't have a very high fire resistance, but can lock in smoke and fire for a shorter period. Hot gases from the initial fire always collect under the ceiling.

Those gases easily move into a corridor with a temperature of 300-400 °C. When mixed with the air inside the corridor, it constitutes an explosive mixture. If an ignition happens now, and there is no compartmentation in the corridor, the fire will rapidly spread over a long distance. The fast spreading of smoke will make evacuating through a building nearly impossible, and extremely dangerous for those who still have to escape. What's more, the smoke will surely leave you with severe health problems, if you are ever able to get out of the building.

NOT LONG AGO, FIRE TESTING WAS NOT OFFICIALLY REGULATED. WHAT DID A TYPICAL FIRE BEHAVIOUR TEST LOOK LIKE?

Different countries developed different test methods to evaluate products and not many international standards for testing existed. That became a real problem once we started the European Union, which promoted free trade, and thus the free movement of goods. ▶



Performance of SBI test



Gas burner



Gas supply

FIRE PERFORMANCE TRESPA® METEON®

Trespa is committed to the safety of its processes and products. Two classes of Trespa® Meteon® are available: Standard^A grade and enhanced Fire-Retardant grade (FR). Trespa® Meteon®'s standard delivery programme complies with European Standard EN 438-6 and has been accepted for the European Economic Area (EEA) mandatory CE mark according to the EN 438-7.

Trespa® Meteon® meets stringent regulations for consumer safety, health and environmental issues in many markets around the world, certified by such institutes as KOMO, DIBt, BUTgb, BBA, CSTB, Torroja and UL.

PROPERTIES	TEST METHOD	PROPERTY OR ATTRIBUTE	UNIT	RESULT <input type="checkbox"/>	
				Grade: EDS (Meteon®)	Grade: EDF (Meteon® FR)
				Standard: EN 438-6	Standard: EN 438-6
				Colour/Decor: All <input type="checkbox"/>	Colour/Decor: All <input type="checkbox"/>
Europe					
Reaction to Fire	EN 438-7	Classification $t \geq 6$ mm / 0.2362 in Classification $t \geq 8$ mm / 0.3150 in (Metal Frame)	Euroclass	D-s2, d0	B-s2, d0 B-s1, d0
Reaction to Fire (Germany)	DIN 4102-1	Classification	Class	B2	B1
Reaction to Fire (France)	NF P 92-501	Classification	Class	M3	M1
North America					
Material Surface Burning Characteristics <input type="checkbox"/>	ASTM E84/UL 723	Classification Flame Spread Index Smoke Developed Index	Class FSI SDI	n.a. n.a. n.a.	A 0-25 0-450
Asia Pacific					
Reaction to Fire (China)	GB 8624	Classification	Class	D-s2, d0	B-s1, d0, t1

Availability limited - contact your local Trespa® representative for more details.

All data are related to the products mentioned in the Trespa® Meteon® standard delivery programme.

Laboratory test results are not intended to represent hazards that may be present under actual fire conditions. For multi-story applications, where local or national building codes may require full-scale fire testing in accordance with NFPA 285(U.S.) or Can/ULC-S134 (Canada), please visit our website www.trespa.info or contact the Technical Service Department of Trespa North America at 1-800-487-3772 for installation information.

PLEASE VISIT TRESPA.INFO FOR THE MOST UP TO DATE INFORMATION.

When I started my PhD thesis on test methods in 1972, I began collecting the different national and international standards and the different test methods on the behaviour of fire available. I gave up when I collected over 100 different, in some way standardised methods. In order to realise a free movement of construction products the European Commission published in early 1989 the Construction Products Directive, or CPD. All construction products had to be characterised according a European product standard. The European Commission decided to regulate all characteristics, such as acoustics, insulation and mechanical stability. But the real problem started with the fire issue. Because you had so many test methods and different requirements, it was impossible to export building materials.

The Commission therefore appointed several experts from national regulators in different countries to develop and agree a new classification system for reaction to fire with the intention to make it into one system. Together with some colleagues I was then asked to develop a new testing method from

the given requirements, which resulted in the Single Burning Item (SBI).

CAN YOU EXPLAIN A BIT MORE HOW THE SBI TESTING METHOD WORKS?

The specification for developing this test was to simulate a paper basket fire in a corner of

“There is an on-going process to make the SBI test an international, ISO standard”.

the room, to measure the heat and smoke release and to design a classification system out of the results. The classification system had to correspond with the large-scale scenario of the room corner fire. In reality, we don't use a basket but a gas burner mounted in a corner section. We measure the rate of heat release indirectly by measuring the oxygen

consumption. For every oxygen molecule that is used, an amount of energy is deliberated. This method was already used in a research test, but not yet in day-to-day testing.

HOW CAN THE RESULTS OF THE SBI TEST PREDICT WHAT HAPPENS IN THIS ROOM CORNER?

The room corner is a reference scenario simulated in a room with a fixed inner size of 3.6 m x 2.4 m x 2.4 m. We did a study for the commission to identify physical characteristics of fire that occur in similar circumstances. From that, we have tried to distinguish large-scale scenarios representing these different situations.

IN WHAT WAY ARE THE EUROPEAN TESTING METHODS SIGNIFICANTLY DIFFERENT FROM TEST METHODS IN, FOR EXAMPLE, THE USA?

There is an on-going process to make the SBI test an international, ISO standard, but this process is slow. In the USA, they currently work more often with the Cone Calorie meter and other test methods. The Cone Calorie meter is only testing the product, not the

product in its end use application. The SBI test on the other hand tests the product in its application.

PEOPLE ACCEPT LITTLE RISK NOWADAYS, AND SAFETY IS BECOMING MORE AND MORE AN IMPORTANT ISSUE. HOW DO WE SEE THIS PHENOMENON REFLECTED IN THE BUILDING INDUSTRY?

Yes, safety in general has become an important issue. Nowadays there are many rules concerning safety, of which fire is one of the aspects. I would say not only safety, but also wellbeing has gained a lot of importance in the work place. Did you notice how many people work as safety employees in and around buildings nowadays?

HOW DO ARCHITECTS, BUILDERS AND CONTRACTORS DEAL WITH THE FIRE REGULATIONS AND FIRE SAFETY MEASUREMENTS?

We are moving more and more away from prescriptive regulations. Instead the regulators rather put forward targets. It is up to the architects and their advisers to make proposals, and prove that with their design they could reach the targeted goal. One target could be that people should be able to get out

the building within two minutes after the fire alarm goes off. The designers must prove that with that design everybody can be out in two minutes. It is up to the client to decide how to spend his money; a fire insurance with a very high premium, or on fire safety measures for the building and its users.

WHAT FUTURE DEVELOPMENTS DO YOU EXPECT IN TERMS OF FIRE TESTING AND FIRE ENGINEERING?

I don't expect major changes in fire testing. We now have a package that is harmonised for entire Europe. It contains logic, and is physically good. Any new material can now be tested and classified. I think it will last for another couple of decades. But in terms of fire safety engineering, I see improvements possible. Ten years ago, in 2002, there was an important seminar held in Luxemburg (BENEFEU – The potential Benefits of Fire Safety Engineering in the EU) where the European Commission was trying to promote the idea of fire safety engineering rather than prescriptive regulations. The European Commission replied that experts don't have to wait for the Commission to take initiatives. However, ten years after the congress nothing much has changed yet. But now we are in

the process where modern architecture can no longer deal with such strict prescriptive rules. I see we are gradually changing towards performance-based rules to prove that a design is safe, or at least safe enough. ■

Please note that the views and opinions expressed in this article are those of the authors and do not necessarily reflect the official policy or position of Trespa International B.V.

NEW UNI COLOUR

**A06.5.1
TOSCANA GREIGE**

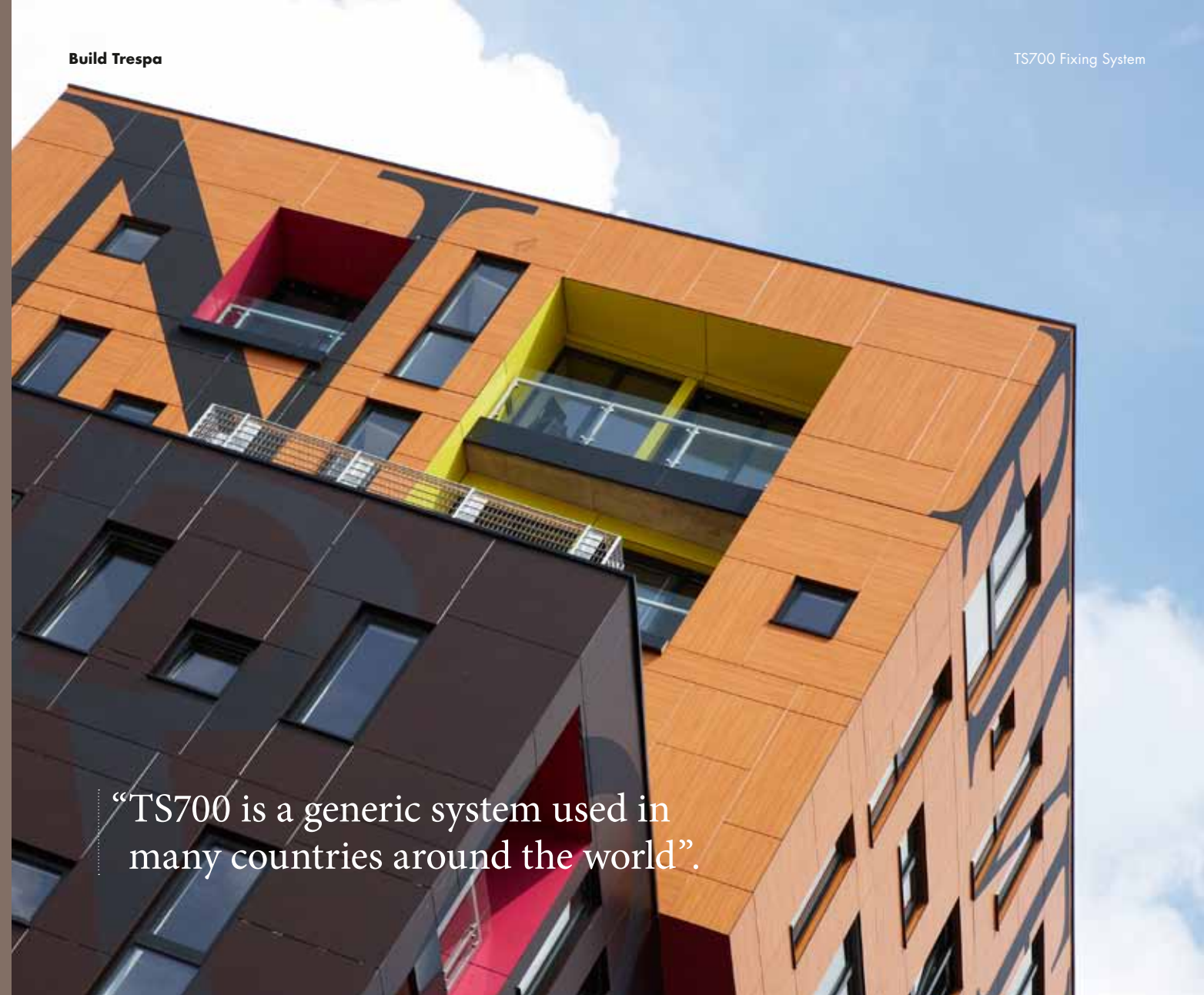

“TS700 is a generic system used in many countries around the world”.



TS700

VISIBLE (EXPOSED) FIXING WITH RIVETS
ON A METAL SUB-FRAME

THE TS700 FIXING SYSTEM OFFERS CONTRACTORS A FAST AND EASY INSTALLATION METHOD FOR TRESPA® METEON® PANELS. IN ADDITION, IT GIVES ARCHITECTS A WIDE CHOICE OF DESIGN POSSIBILITIES. AS WELL AS BEING COST EFFECTIVE, THE SYSTEM IS DESIGN FRIENDLY. IT ALLOWS TRESPA® METEON® TO BE USED IN A WIDE VARIETY OF DIMENSIONS AND THICKNESSES – AS FAÇADE CLADDING, BALCONY PANNELLING OR ON HORIZONTAL EXTERIOR CEILING APPLICATIONS. ▶



ALSOP ARCHITECTS
CHIPS APARTMENTS,
MANCHESTER, UK

An insulated façade using the TS700 system can be completed in four simple steps. With this straightforward approach, on-site labour costs and the possibility of complications are reduced. A strong and durable metal sub-frame prevents any complications in the foreseeable future.

HORIZONTAL CROSS-SECTION

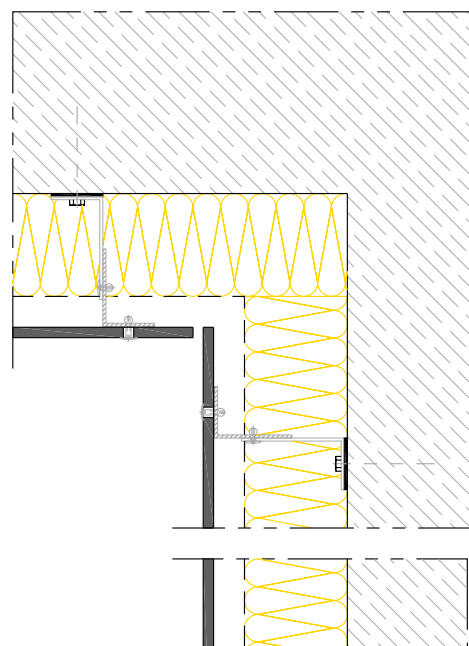
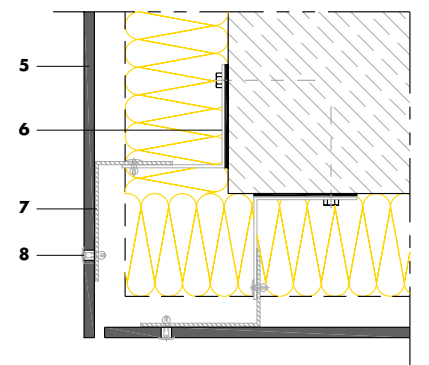
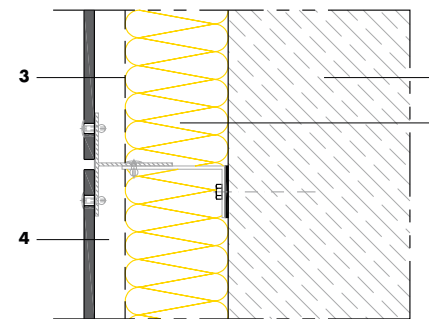
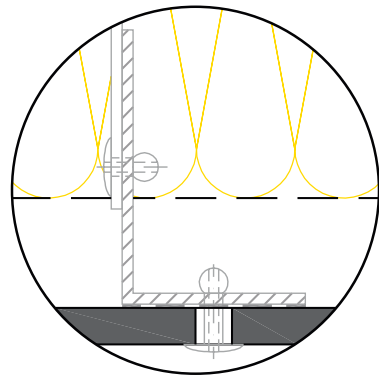

- 1 LOAD-BEARING WALL (CONCRETE, MASONRY)
- 2 THERMAL INSULATION
- 3 WEATHER BARRIER (VAPOUR PERMEABLE)
- 4 VENTILATED CAVITY
- 5 TRESPA® METEON® PANEL
- 6 WALL BRACKET
- 7 VERTICAL RAIL
- 8 RIVET

TO INSTALL THE FAÇADE

- 1 Wall brackets, spaced depending upon the width of the specified panel, are fixed to the load-bearing wall.
- 2 Insulation and a vapour barrier are installed with holes in the insulation allowing the wall brackets to poke through. This step is only applicable if insulation is specified for outside the load-bearing wall.
- 3 Vertical rails are then attached to the wall brackets. For continuous ventilation, Trespa recommends the cavity depth to be between 20 and 50 mm, in order to allow for ambient air to flow through from the ventilation inlets and outlets.
- 4 Trespa® Meteon® panels with pre-drilled holes are attached to the vertical rails by using powder-coated rivets (available in a wide range of Trespa® colours via third parties).



TS700
VISIBLE (EXPOSED) FIXING
WITH RIVETS ON A METAL
SUB-FRAME

“With only a few installation steps TS700 saves installers time and minimises complications”.

DRILLING JIG



SPACER NOSEPIECE



DRILLING JIG

When fixing the panel a drilling jig must be used to make sure that the rivets are always centered in the holes.

SPACER NOSEPIECE

When fixing the panel at sliding points a spacer nosepiece must be used. This tool makes sure that there is the recommended 0.3 mm gap between the rivet and panel surface.

SUB-FRAME

Trespa® Meteon® panels must be installed on a sub-frame of sufficient strength and permanent durability. Quality and/or treatment of the sub-frame must be in accordance with applicable building standards, regulations and certificates.

AVAILABILITY

TS700 is available in the following countries: The Netherlands, Belgium, Germany, UK, Italy, Spain, France, Chile and China*.



FOR MORE INFORMATION
[TRESPA.INFO](https://www.trespa.info)

* NOTE This does not suggest, represent or indicate compliance with relevant building codes or certification. Not all certification required for your project may be available through Trespa or additional certification may have to be obtained by the customer. Therefore, also in relation to the above overview, Trespa strongly advises that the customer, project owner and architect seek independent advice from a certified construction professional and/or engineer regarding the accordance to national and/or local building regulations of a chosen fixing system.

FIXING DETAIL

- SHANK DIAMETER OF THE RIVET IS 5 MM.
- HEAD DIAMETER OF THE RIVET IS 16 MM.
- HOLE DIAMETER FOR FIXED POINT IS 5.1 MM.
- HOLE DIAMETER FOR SLIDING POINTS IN THE PANEL IS 10 MM.
- THE RIVET HEAD SHOULD BE 0.3 MM FREE FROM THE PANEL SURFACE BY USING A SPECIAL TOOL (SPACER NOSEPIECE).
- RIVETS MUST ALWAYS BE CENTERED IN THE HOLES BY USING A DRILLING JIG.
- TO RETAIN THE PANEL POSITION, EACH PANEL MUST HAVE ONE FIXED POINT IN THE CENTRE OF THE PANEL. ALL OTHER FIXING POINTS ARE SLIDING POINTS.

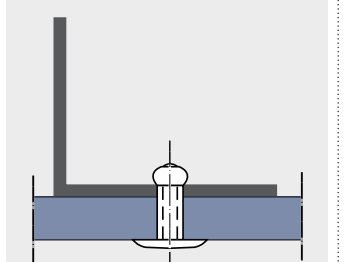

FIXED POINT

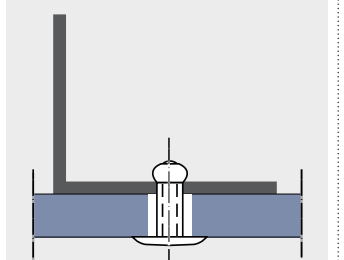

SLIDING POINT

TEXT MARK STUDHOLME

ENDURING THE TEST OF TIME

IN TODAY'S ARCHITECTURE, LONGEVITY IS A KEY CONSIDERATION, AS ANY BUILDING THAT REMAINS LOOKING GOOD OVER TIME WILL CONTINUE TO COMMAND ATTENTION. BUT AS WELL AS TO AESTHETIC CONSIDERATIONS, THERE ARE ALSO COST IMPLICATIONS: A REDUCED NEED FOR MAINTENANCE BRINGS ADDITIONAL SAVINGS IN LABOUR COSTS AND CLEANING MATERIALS.

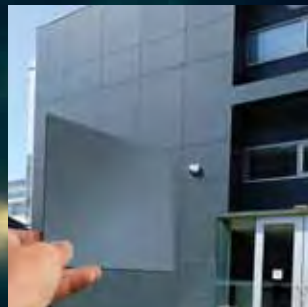

A NEWLY PRODUCED TRESPA® METEON® SAMPLE COMPARED WITH THE SAME COLOUR ON A 20 YEAR OLD BUILDING.



Architects who are looking to create exciting and highly individual façades have long recognised that Trespa® Meteon® is a unique material that can make buildings stand out. The material's inherent characteristics have inspired architects and designers to create outstanding and innovative buildings all over the world.

ELECTRON BEAM CURING TECHNOLOGY

One of the most important events, both for Trespa and for the architectural world in general, was the introduction of Electron Beam Curing (EBC) for the surface finish of HPL. Developed in-house and patented by Trespa, this process was designed to create a completely new type of surface by significantly improving the performance of the former panel's melamine surface. It not only gives the panel as near perfect a surface as possible, but also adds exceptional colour stability and high resistance to damage.

Once the colours are mixed, they are applied to a sheet of impregnated Kraft paper. This decor, applied on a PET foil, is then fed through the Electron Beam Accelerator which hurls electrons at such a high speed that the surface hardens in less than a second. The clever EBC process is designed to ensure that Trespa® Meteon® will retain its outstanding appearance and original freshness for many years. The panel is weather resistant, and neither sun, nor rain (including acid rain) nor moisture has any significant effect on its surface, which is virtually maintenance free. ▶



COATING FOLLOWED BY ELECTRON BEAM CURING CREATES AN EXTREMELY SMOOTH AND CLOSED SURFACE

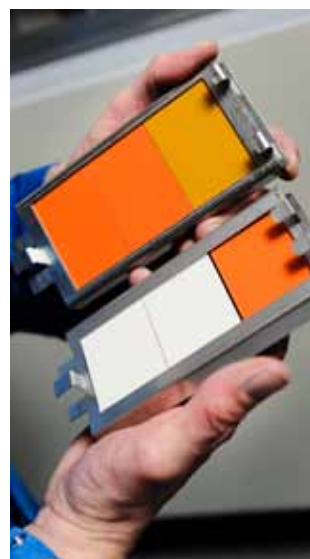

EVALUATION OF EXPOSED SAMPLES FROM THE WEATHEROMETER. THESE SAMPLES WILL THEN BE REMOVED FROM THE HOLDER AND VISUALLY COMPARED TO ORIGINAL SAMPLES TO ASSIGN GRAYSCALE VALUES.

ARTIFICIAL AGEING

Every product manufactured by Trespa undergoes extensive testing in the laboratory before it is brought to market. A number of tests measure and prove Trespa® Meteoron®'s resistance to a variety of influencing factors including sun, rain and impact. One of the most important Trespa tests is artificial ageing, which is the primary test that allows Trespa to guarantee product longevity.

Trespa has three weatherometers, which artificially age samples of the product. Each sample spends 3000 hours in the machine, rotating around a Xenon lamp. The lamp simulates solar radiation. Once the sample is taken from the machine, it has undergone the equivalent weather ageing of 10 years in the extreme weather conditions of Florida. This sample is then compared with an original sample first by a computer, and then by eye.

The technician evaluates the difference in grayscale between the samples. If the grayscale has a minimum of four (minimal colour change) the product's longevity can be guaranteed, assuming all other tests are passed.

GOOD LOOKS OVER THE YEARS

To illustrate the long life performance of its panels, Trespa recently revisited three Trespa® projects in Europe (the District Police Station at Rotterdam Zuidplein and the UMC St Radboud Hospital in Nijmegen, both in The Netherlands, and the University of Barcelona campus in Spain) that were completed many years ago. Samples of the original façades were compared to newly produced Trespa® Meteoron® panels, and results revealed that at these projects, the Trespa® Meteoron® has retained its outstanding good looks over the years. ■

DISTRICT POLICE STATION

ROTTERDAM, THE NETHERLANDS

Built in 1988, revisited in 2011 - The District Police Station at Rotterdam Zuidplein, The Netherlands was designed and built in 1988. The building's facility manager confirmed that material comparisons proved that the façade's original colours had barely faded or changed.

"The building is close to a main road and near a metro station, as well as being very close to Rotterdam harbour, the biggest and busiest in Europe. This type of location places high demands on a façade in terms of pollution, dirt and weathering. In 1988, we selected Trespa® panels. In 2008, when we started work on extending the building, we realised that this was the right choice, because the brand new Trespa® panels made 20 years later perfectly matched the originals. Overall, the insulation, back construction and panels were still in perfect shape".

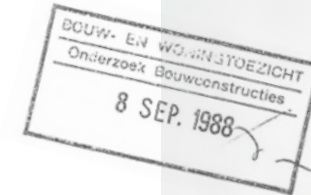

CENTRE DE CÀLCUL

BARCELONA, SPAIN

Built in 1991, revisited in 2011 - The Centre de Càlcul was built in the University of Barcelona Campus in 1991, to house the centralised computer services of the University. It contains the Data Processing Center and links to all faculties. The building, which covers 4.200m², was partially clad with Trespa® Meteoron® panels. Asked about the building today, its architect, Jordi Fabré says:

"Overall, the building still looks good, similar to the way it looked on the first day, with noble ageing. I would say that the image still matches the conceptual design. Regarding the Trespa® panels, I felt comfortable with the material at the time - and looking at the building again, they have performed very well".





“We host wonderful events with some of the best known and most innovative designers and thinkers of today” . *Nicolas Rojas*

TEXT WILL JONES

THE CURIOUS CASE OF THE **DESIGN CENTRE** IN SOHO

PASSERSBY PEER IN, CURIOSLY. TO ANYONE NOT IN THE DESIGN OR CONSTRUCTION BUSINESS THE YELLOW AND BLACK SIGN THAT READS TRESPA | ARPA COULD BE ANY NUMBER OF THINGS; A FASHION OUTLET, AN ART GALLERY, EVEN A RESTAURANT. SO, THEY PEER IN THROUGH THE PLATE GLASS WINDOWS, WONDERING.

SOMETHING DRAWS ME IN

Set within the trendy SoHo warehouse district of New York, the Trespa Design Centre is located amidst the creative hub of Manhattan Island. What, in the late 19th and early 20th Centuries, were textile and dry goods warehouses, have become the home to trendy boutiques, commercial galleries and high-end fashion stores for major international brands. New Yorkers and tourists alike are attracted to the area by its eclectic mix of big brands and quirky labels, the prospect of buying something astronomically expensive or finding the ultimate bargain. They stroll down cobbled streets and gawp at the grandeur not of sky scrapers but of the classically inspired cast iron façades, an architectural trend that proliferated in the late 19th Century due to its low cost and ease of manufacture. Today, however, it is admired for its decorative appeal, a touch of glamour that survived a time when manufacturing was the mainstay of a district known as Hell's Hundred Acres.

Standing outside 62 Greene Street, I also peer in curiously. I know what the design centre is but I wonder what will I find inside? What kind of event does the centre offer? What is the reasoning behind a product manufacturer opening a design centre, and doing it in the midst of a global recession, too?

There's only one way to find out, I guess and so through the ornate façade, between the cast iron columns topped with scrolled capitals I go, into another world. A monochromatic world, a clean, crisp space in black and white, which is interspersed objets d'art – a contemporary Dutch take on a chandelier, quirky kitchen module or other furniture piece – and empowered with bursts of colour, the brightly hued variations of the exterior solutions offered by Trespa and the interior solutions offered by Arpa. The partnership of the two names on the sign now makes a lot of sense; both brands complement each other's products. But still I am curious about this Trespa Design Centre New York.

THE MAN BEHIND THE DOORS

Meeting Nicolas Rojas, Events Coordinator for the venue, might, I think, assuage some of my curiosity. He'll be able to give me the lowdown on just what goes on here, I'm sure. However, as we discuss his role and how he came to work at the Design Centre I realise that he too was drawn to Trespa out of curiosity.

After studying architecture and design, Rojas found employment with the Municipal Arts Society, within its Urban Center. There, he worked on creating events, inviting architects and authors to discuss and present their ▶





“We are always curious. We are curious about what’s going on out there: about new talent; about new design”. *Nicolas Rojas*

THE REASON IS NEW YORK

“But why do this in New York when Trespa’s root is in Europe?” I ask Kimmel. “We had made inroads into the US market but realised that there were many more opportunities to be had. Market research revealed that of the big US cities New York was the epicentre of

work to the design communities in an open forum for the general public. “I then moved to Phaidon Press and The Monacelli Press where I continued to work within the publishing industry, promoting books and book related events but all the while I had a yearning to reconnect with my architectural roots, to regain a foothold in the architectural world”. Rojas saw his opportunity when he spied the position at the Design Centre. “I was intrigued enough to apply and found that the role would give me the opportunity to work on special events, programmes and lectures that would bring me right back into the architectural world. I jumped at the chance and took the job”.

Rojas now works alongside Business Development Manager Todd Kimmel and together the duo have embarked upon a series of events that strive to both engage the architecture and design establishment of New York, its surrounding area, and garner new business for the parent company.

Kimmel is quick to divulge the mission statement of the Design Centre, “We want to showcase Trespa as high-end brand and to do this we have made available the Design Centre to architects and designers, as a space to be inspired in. Our mission to generate business is no secret but we aim to do it via the soft sell while showcasing great design and practitioners. When an architect, designer or installer visits the centre they can hold the materials in their hands, learn about fixing system solutions and have access to a wide range of support. For these reasons many visitors find the Design Centre a valuable experience”.

the design world. There is a high density of architects; there is a high interest in design and innovation from professionals and the public; the city has good public transport systems; and, being on the east side of the US, New York has easy international transport links with Europe”.

“Within the city, SoHo has a historical connection with the manufacturing industry and with the design and artistic community. It is also now the home of many internationally known high-end brands, and as such, is the perfect place for Trespa to be positioned,” believes Kimmel.

Rojas agrees, stating that he regularly fields questions from highly design literate individuals who just happen to be passing. “Like you and me, they are curious of this brand, this centre,” he says. “And so they should be because we host some wonderful events with some of the best known and most innovative designers and thinkers of today”.

DISCOVERING THE SPACE AND WHAT IT OFFERS

And that brings us to what the Design Centre actually does. With some 8000 sqft of space, the venue can host up to 150 people at any one time. Its layout makes it possible to hold large parties – a recent one was during the International Contemporary Furniture Fair – or stage intimate discussions or debates. “Initially, we partnered with established organisations within New York, allowing them to use our space in order that we could get to know people and become known as a venue of choice,” says Kimmel. “We partnered with the American Institute of Architects, the US Green Building Council and the Architectural League of New York in talks, debates and other events”.

Now, however, the Design Centre is intent on putting on its own programme, alongside

the ongoing partner events, and this is where the combination of Rojas’ event coordinating skills and Kimmel’s business development knowledge gel.

The events are tailored to attract different sectors of the business and design conscious community. On one hand there is the



‘A Conversation With...’ series; discussions between well known figures in the design world, which are open to the public. “They are a magnet for people who are curious to find out what’s going on out there and a chance for us to gauge interest in specific topics,” says Rojas.

Conversely, regional or sector based events target a specific market and are often populated by an invited audience. Kimmel explains: “We recently brought a group of architects from Florida to the centre to talk to them about the benefits of using our products specific to their region. And, similarly, we held a series of talks for architects in the education sector”.

“These events are really focused on products and technologies that Trespa can provide. They target a market sector and provide everything that an architect in that sector needs to know. And they work, too. We’ve had some great referrals following them”. A recent series of talks that drew interest from professionals and public alike was the Appetite for Design series. For this, Rojas teamed chefs with the architects who designed their restaurants and asked both how the other influenced the way they worked.

“We asked them, how does the architecture affect the food that you create and vice versa. The answers were really interesting and often surprising,” says Rojas. “We recently hosted a 3-day seminar entitled Building Brand: Architecture and Corporate Identity. We invited the senior director of design for Hilton Hotels and Resorts, the principals from Pentagram, and the editor of Contract magazine to speak. And then, there’ll be other events coming up that will showcase the work of new and innovative firms, the people who are challenging convention and designing for tomorrow. These events are useful for the people but also Trespa, by using the knowledge collected they can further their own services. By responding to the needs of their network they can always make sure that what they offer is the best”.

HOW CURIOSITY DEFINES

“Reaction to the Trespa Design Centre and the events it hosts has been wholly positive”, says Rojas, who collects and avidly reads visitor satisfaction surveys. He tells of how people appreciate both the subject matter of the events and lectures and the space in which they are held.

“This sums up what we are doing so well,” he says, reading from a recent survey ‘the

informal nature of the space makes an architecturally relevant event all the more interesting. The Design Centre is heading in the right direction – taking note of what designers want, what they want to know and who they want to see’. “That’s great to hear, don’t you think?”

And there it is, in his voice, an excitement and passion to make the Design Centre a success. I ask him to state in a few words what it is that will achieve that success and his answer makes me smile.

“At Trespa we are always curious. We are curious about what’s going on out there: about new talent; about new design. I am, we are, always curious to know more about the design world and that will draw likeminded people – the people who are at the forefront of their respective fields - to us. Curiosity: that is what will make the Design Centre a success”.

NEW UNI COLOUR
A05.5.0
QUARTZ GREY



NEW UNI COLOUR
A12.1.8
PASSION RED



TEXT JEANNE TAN

VELVE-LINDENHOF ACTION PLAN PASSIVE HOUSE

HOW TO REALISE A LARGE-SCALE PASSIVE HOUSE DEVELOPMENT THAT IS QUICK TO BUILD, HAS LOW LIFE-CYCLE COSTS, MAXIMISES FLOOR AREA AND REDUCES EXPENSES.



“Through the use of Trespa® Meteon®, it’s possible to complete a façade within a short period of time”. *Marcel Besten*

THE AMBITIOUS NEW HOUSING DEVELOPMENT OF GROEN VELVE-LINDENHOF IN ENSCHEDE AIMS TO PROVIDE A SUPPORTIVE ENVIRONMENT FOR ITS RESIDENTS BOTH INSIDE AND OUTSIDE THE HOME. COMMISSIONED BY HOUSING CORPORATION DE WOONPLAATS, THIS IS THE LARGEST ‘NEW BUILT’ PASSIVE HOUSE PROJECT IN THE NETHERLANDS, MARKING A SIGNIFICANT RECOGNITION OF THE NEED FOR SUSTAINABLE CONSTRUCTION ON A LARGER SCALE. DESIGNED BY BELTMAN ARCHITECTEN, THE PROJECT DEMONSTRATES HOW ARCHITECTURE CAN CONTRIBUTE TO CREATING POSITIVE ENVIRONMENTS FOR ITS COMMUNITIES. ▶

Enschede, the Netherlands



About the Project

PRINCIPAL

DE WOONPLAATS

MAIN CONTRACTOR

DE GROOT VROOMSHOOP
HOUTBOUW B.V. / TE PAS BOUW

INSTALLER

BIJBOUW

BUILDING PHYSICS CONSULTANT

NIEMAN RAADGEVENDE
INGENIEURS

ARCHITECT

BELTMAN ARCHITECTEN

YEAR

2012

MARKET SEGMENT

INDIVIDUAL HOUSING

PRODUCT

TRESPA® METEON®
WOOD DECORS

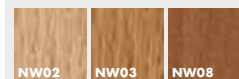

5 PROJECT COLOURS

FINISH

SATIN

FIXING SYSTEM

TS550

The neighbourhood of Velve Lindenhof is currently being renovated in a bid to improve the socio-economic circumstances of its residents and rejuvenate the physical surroundings. To achieve this, the residents, together with the municipality of Enschede and housing corporations, drafted the 'Actieplan Velve-Lindenhof'. The plan addresses the needs of the community through keeping operating costs low, new sustainable housing and providing a nurturing environment. A part of the redevelopment comprises 211 new low-cost houses, 82 of which will receive the Passief Bouwen certification. From the outset, the residents were active in all areas to help shape their new housing.

“We want to make sure that the energy bills here remain affordable”. *Marcel Besten*

BENEFITTING THE LONG AND SHORT TERM

A low cost of living remains a major consideration for these residents. Architecture can contribute to reducing that through addressing the building's life-cycle costs, of which long-term operating costs comprise a big chunk. According to De Woonplaats,

energy efficient housing is the best way to minimise this expense, especially concerning winter heating. “In the coming years, energy prices are expected to increase,” says Marcel Besten, project manager at De Woonplaats. “We want to make sure that the energy bills here remain affordable”. Maintenance needs also add to rising household expenses. Therefore the choice was made to build the new houses according to Passive House principles which focus on minimising energy loss and reducing energy usage. A smart choice of materials for sustainability and durability completes the picture.

To minimise heat loss, these houses – there are six types – are equipped with a tight thermal envelope created by heavy insulation and good air tightness combined with triple glazing. Heating requirements are minimised through southern orientation to maximise passive solar gain, a heat recovery ventilation system and solar thermal collectors for hot

water. For summer cooling, openings in the stairwell expel hot air. Residents are also provided with regular guidance about energy saving. This means the total EPC value (energy performance index) will not exceed 0.4 (standard is 0.6). This translates into a clear architectural strategy: open southern-

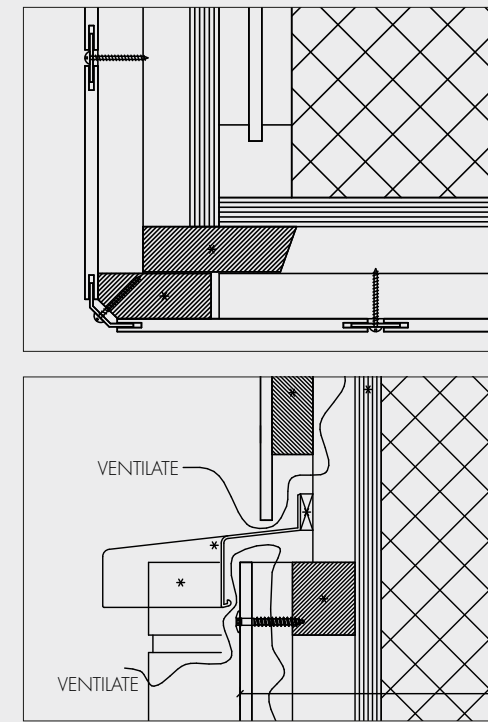

Two examples of the façade construction from the inside to the outside.

facing façades with generous openings housing living functions and more closed northern-facing façades accommodating service functions. According to Beltman Architecten, the architecture here is utilised as a medium to express the message of passive building.

MINIMISING WEIGHT, MAXIMISING FLOOR AREA AND REDUCING TIME

To support the project's construction, environmental and economic aims; innovative construction methods were needed. Three main construction considerations were: minimising weight (reducing pressure on the foundations), minimising wall thickness (increasing floor area) and fast installation (reducing on-site construction time and effort). In this way, a lightweight prefabricated FSC timber frame system devised by De Groot Vroomshoop Houtbouw B.V. with a panel façade of Trespa® Meteon® provided the solution. “A Passive House requires optimal insulation and this increases the wall thickness,” explains Harm Valk from Nieman Raadgevende Ingenieurs. “By using a sheeted façade, this delivers a saving of 8-10 cm in wall thickness in comparison with brick masonry”. The prefabricated frame enables speedy construction as the whole structure is delivered ready-made to the site. “Therefore it's possible to build one house per day,” says

“This delivers a saving of 8-10 cm in wall thickness in comparison with brick masonry”. *Harm Valk*

Besten. “Through the use of Trespa® Meteon®, it's possible to complete a façade within a short period of time and there is no wastage remaining because the panels are delivered ready-made on site”. Known for its durability the material ticked all the right boxes regarding the façade's longevity, needing minimal replacement and maintenance during the building's life span. Valk adds another technical advantage: “From the standpoint of fire safety (fire spread) between the houses, Trespa® Meteon® is a good choice because it requires no additional treatments for fire-proofing”.

CREATING A NATURAL LOOK

The choice of Trespa® Meteon® supports the long-term vision of the project while creating a distinctive identity for the new neighbourhood. The three types of Trespa® Meteon® (NW02, NW03, NW08) cut precisely into vertical boards, are attached invisibly to create a flush façade – the screws are fastened in the connecting strips. Valk: “Through

the tight measurements, a permanent detailing solution is possible which supports the low-maintenance character of the façade”. Architecturally, the flexibility of the system enables application across the differing façades to create visual unity while offering variations

in finish and colour. Besten explains: “The three different timber shades used in random sequence, in combination with the dark brickwork, create a visual variation. A natural ‘green’ atmosphere will result once new trees are planted in front of the houses”. Koert Helman from Beltman Architecten echoes the same sentiment: “The neighbourhood has a very natural look and exudes a certain warmth”. Feedback from the residents confirms they are very positive about their new homes: happy residents equal well-cared-for buildings delivering priceless benefits in the long run. ■

Please note that the views and opinions expressed in this article are those of the authors and do not necessarily reflect the official policy or position of Trespa International B.V.

VENTILATED FAÇADES

INSPIRED BY NATURAL SYSTEMS

VENTILATED FAÇADES HAVE BEEN AROUND FOR A LONG TIME. IN TRADITIONAL SCANDINAVIAN HOUSING, FOR EXAMPLE, AN AIR GAP WAS INCLUDED BETWEEN THE TIMBER EXTERNAL WALL AND THE INTERNAL WALL, AS A WAY OF PREVENTING THESE SOFTWOOD STRUCTURES FROM ROTTING IN A RAINY CLIMATE. BUT THE PRINCIPLES GO BACK FURTHER THAN THAT – IN FACT, THEY TAKE THEIR CUE FROM THE NATURAL WORLD.



THROUGHOUT NATURE A SKIN PROTECTS AND IS A MEDIUM BETWEEN THE INSIDE AND OUTSIDE.

Throughout nature you will find protective membranes or skins. Animals, trees and even planets all have skins that protect their internal systems. Not only do these skins protect but they also act as mediums between the inside and the outside. Systems in these natural skins permit the transfer of certain elements such as vapour from one side to another, allowing them to “breathe”.

Until recently most buildings have had sealed envelopes rather than breathable skins. Their primary function was to protect the indoor space from the outdoor environment. Sealed envelopes can cause problems for a building if they leak or if there is inadequate ventilation. Leakage can cause deterioration of the (inner) wall construction. Due to the inner wall being out of sight this leakage is often discovered too late resulting in a high cost of repair.

Today, ventilated façades are applied worldwide as an answer to allowing a building to “breathe”. They enable architects to meet the requirements in different climates. By introducing a ventilated air space between the cladding and the construction, vapour can more easily pass between the skins of the building. This contributes to a healthy indoor climate.

A “BREATHABLE” BUILDING

A number of benefits result from allowing the migration of moisture and vapour from the interior of the building into the open air. By letting moisture escape and stopping water penetration, the growth of mold colonies and rot is suppressed; mold can cause respiratory problems and even trigger asthma attacks. Wood rot and metal corrosion, meanwhile, can affect the stability of the structure.

By integrating or even adding a ventilated rainscreen cladding system to a building façade water penetration is minimised, the load-bearing wall is in good condition, internal air quality is improved and insulation can be increased and kept in desirable condition.

This is down to a ventilated air space between the cladding and the load-bearing wall. The air in the designed cavity will circulate due to air pressure differentials and thermal differentials over the height of the building. In a cold climate this causes the condensation water at the rear of the cladding to dry. In a warm climate the moving air will cool the inner layers of the construction, thus reducing the demand for cooling energy.

WATER PENETRATION

With continuous air flow between the cladding and the inner layers of the exterior wall and vertical cavity closures at the corners of the building only small pressure differentials occur between both sides of the cladding.

Penetration of wind-driven rain through the joints of the façade cladding therefore is minimal and ventilation openings permit drainage of rain that might have penetrated through the joints.

THE LOAD-BEARING WALL

A load-bearing wall protected by a ventilated façade system will usually be dry and therefore deterioration is limited. Rainscreen cladding is relatively light in comparison to other wall constructions; this reduces the weight applied to the load-bearing wall.

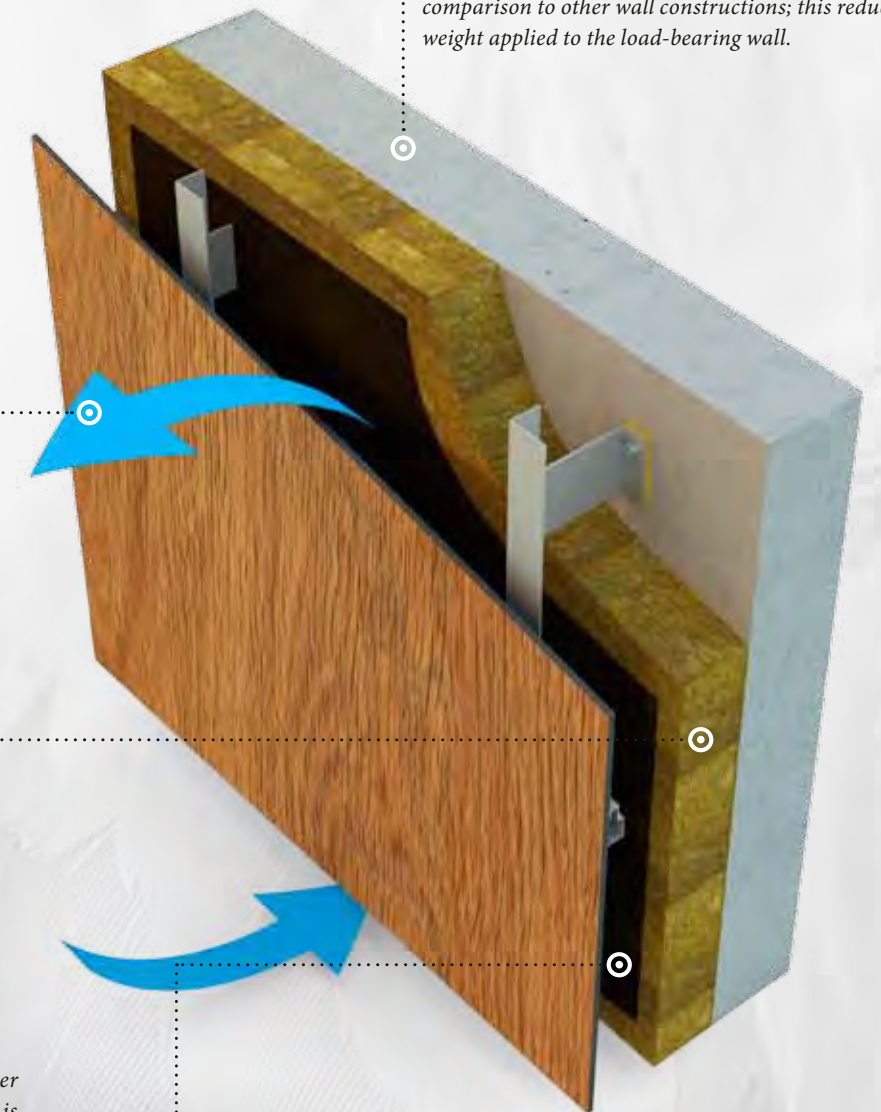

INSULATION

Due to the use of a thin rainscreen cladding rather than standard thicker claddings such as brick, more depth is available for insulation, given a certain thickness of the total wall construction. This extra insulation improves the energy efficiency of the building.

INDOOR AIR QUALITY

In a ventilated façade system, a weather barrier is intended to stop moisture from penetrating the building. This weather barrier may be vapour-permeable, allowing vapour to move between the inside of the building and the outside air, which can help improve indoor air quality. The designer may also choose a weather barrier that prevents air infiltration, thus reducing uncontrolled heat or cold leakage.

NOTE The illustration on this page does not specify a particular system and is only for information purposes. Visit trespa.info for more detailed information.

VENTILATED FAÇADES FIXING SYSTEMS

Fixing Systems

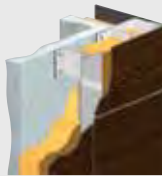
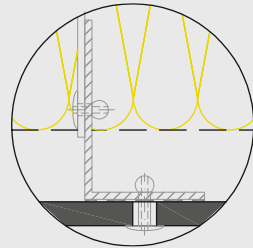

VISIBLE FIXING

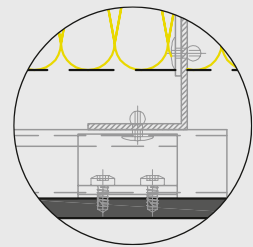

INVISIBLE FIXING

Not all systems are available worldwide, for availability please go to www.trespa.info. Please check your local codes and applicable design requirements for proper use.

CAVITY DEPTH

To integrate the ventilated façade system Trespa recommends a cavity depth of between 20 mm and 50 mm. The vents at the top and the bottom of the façade require a total area of minimum 50 cm²/m¹ (including above and below window openings).

FIXING SYSTEMS

The following fixing systems facilitate the installation of a ventilated façade.

Visible Fixing Systems have exposed fixings such as rivets (as example TS700).

Invisible Fixing Systems conceal the panel fixings, creating an uninterrupted surface (as example TS200).

JOINTS

Joints between panels should be a minimum of 10 mm. This is due to working of the panel material and subframe, caused by differentials in temperature and humidity as a result of outdoor exposure.



MORE INFORMATION CAN BE FOUND AT
TRESPA.INFO

In the next issue of Think Trespa, find out how ventilated façades can make a project more energy efficient and minimise 'thermal bridging'.

Joints



VERTICAL JOINTS

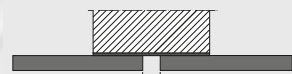

EPDM GASKET



TONGUE-AND-GROOVE

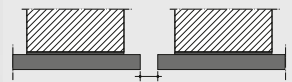

OPEN JOINT

HORIZONTAL JOINTS

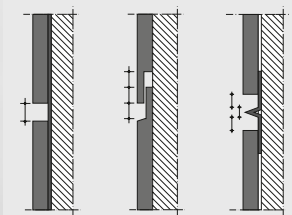

OPEN JOINT

HALVED JOINT

JOINT PROFILE



NEW UNI COLOUR

A37.0.8
LIME GREEN



TRESPA STUDIO PASSION FOR PRODUCT DEVELOPMENT AND FAÇADE SOLUTIONS

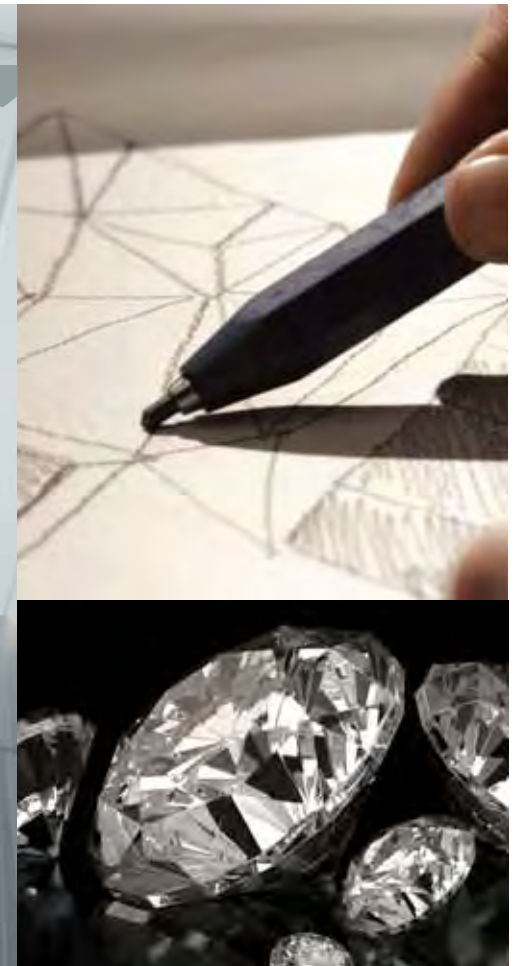

TRESPA STUDIO IS A MULTIDISCIPLINARY PASSIONATE GROUP WITHIN TRESPA INTERNATIONAL BV THAT IS CONTINUOUSLY LOOKING TO DEVELOP INNOVATIVE AND DURABLE PRODUCT AND FAÇADE SOLUTIONS.

Through working with architects and designers, the studio develops new products, new façade ideas and aesthetics, the aim always being to add value. One example is the introduction of nine new Trespa® Meeon® Uni Colours which are carefully chosen and provide more choice to create façades that tell a story. Another example of the group's innovations is Trespa® Meeon® Graphics – a one-on-one tailored service for creating individual and stunning façades with patterns and decors*.

To share your ideas for projects, or if you want to know more about creative solutions with Trespa® Meeon®, please contact Trespa Studio at studio@trespa.com or visit trespa.com.

* Availability limited – contact your local Trespa® representative for more details

PERSPECTIVES

Trespa Perspectives is our communication platform which inspires and provides creative solutions for façade designs. It is based on three themes: Depth, Character and Rhythm. In the following pages you will find a selection of the most inspiring concepts and realised projects developed in cooperation with Trespa Studio. There is a desire within Trespa Studio to be challenged with innovative and daring designs - if you have a design challenge, get in touch. They can help you find a solution.

Depth, Character and Rhythm are themes used to inspire innovative shapes, technique and combinations of colours and materials. Trespa has further deepened these three themes with the concepts of colour, curved elements and light, pushing

the limits of creativity even further. These open up many more possibilities for different and novel shapes, dimensions, combinations and applications. Trespa has strong essential characteristics in terms of durability, maintenance, cost-effectiveness and functionality, making it the perfect foundation to develop inspiring designs. ■

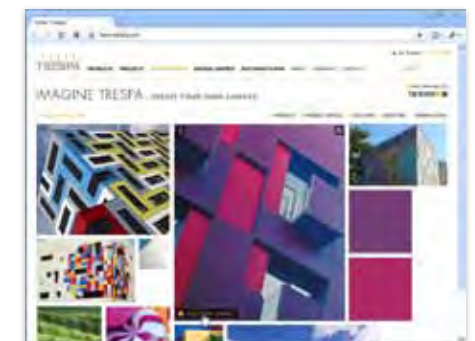

FOR MORE INFORMATION
TRESPA.COM/TRESPASTUDIO

AESTHETIC SKIN

SKIN

A DOUBLE LAYER MAY BE REALISED BY USING SANDWICH PANELS: A STABLE PACKAGE OF TWO PANELS WITH A PROFILE IN BETWEEN. THE POSSIBILITIES DEPEND ON A NUMBER OF VARIABLES:

- BACK CONSTRUCTION AND FIXING SYSTEM
- SIZES OF THE HOLES
- THE AMOUNT OF TRESPA MATERIAL LEFT BETWEEN THE CUT-OUTS
- PANEL THICKNESS

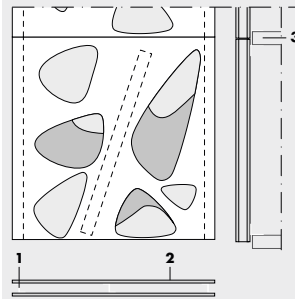

1. METAL Z-PROFILE 2. TRESPA® METEON®
3. MOUNTING SYSTEM

TRESPA® METEON® PANELS CAN BE USED TO CREATE AN AESTHETIC SKIN THAT MAKES YOUR BUILDING STAND OUT. HERE ARE SOME EXAMPLES OF CONCEPTS AND REALISED PROJECTS, WHERE TRESPA® PANELS® ARE USED TO CREATE EXTRA SKINS THAT CHANGE AND ENHANCE A BUILDING'S OVERALL APPEARANCE.



“Aesthetic creativity and liberty is sweeping through today’s architecture. The skin panels that clad the YMCA named Le Prunais, located at Villiers sur Marne (94), embellish this emotional architecture. Born thanks to the collaboration between Trespa and the architect of the project, – Laurent Fournet, – the Skin façade draws the passer-by’s eye, delights the neighbours and fills the renters with joy!”

*Isabelle Pinteau,
Key Account Manager, France*



“Developing new products for architects is always exciting, they do not demand a rigorous specification at the start, but are open to a creative development process”.

*Gerard Zweers,
Trespa Architecture & Design*

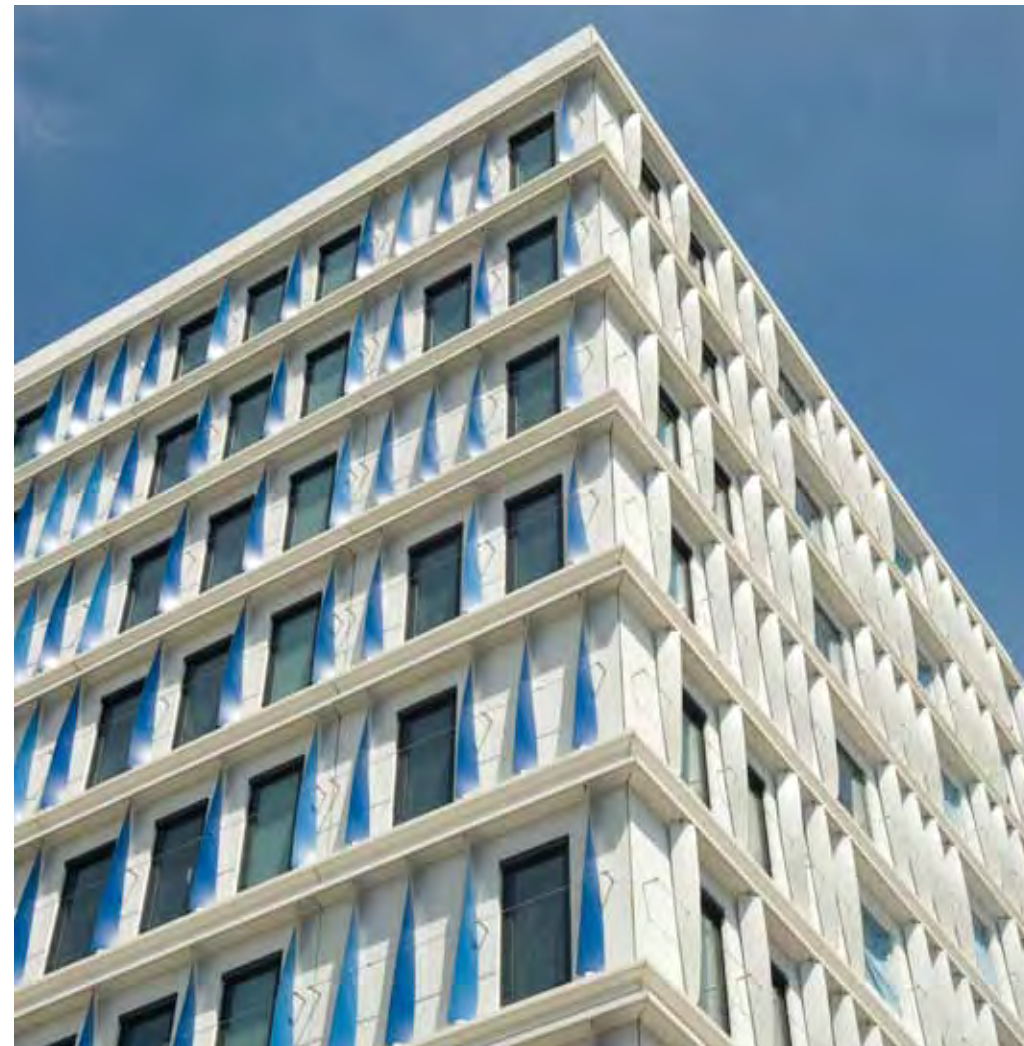

HELIX

HELIX IS A DESIGN BASED ON THE TECHNICAL OPPORTUNITY TO CURVE TRESPA® PANELS.

IN THIS DESIGN, HELIX SHAPED PANELS ARE FIXED IN A RECTANGULAR FRAME. THE STRIPS CAN BE ATTACHED AT THE TOP AND BOTTOM, USING A U-SHAPED PROFILE AND RIVETS OR SCREWS. BY PLACING A HORIZONTAL TUBE THROUGH THE CENTRE OF THE STRIPS, THEY CAN BE POSITIONED BY MEANS OF A SHORT TUBULAR PROFILE.

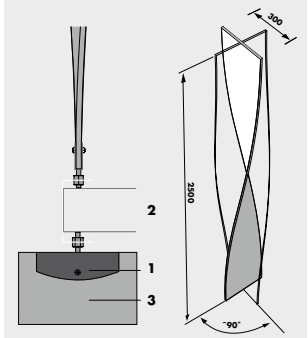

1. U-PROFILE 2. STEEL CONSTRUCTION
3. TRESPA® METEON® 10 MM



NOTE The designs shown are for inspiration only and have not been submitted to specific tests. Actual designs may vary, depending on specific location, regulations and circumstances. Design and fixing systems may influence possible end results. Trespa® Meteoron® is CE marked and fully complies with the EU standard. Always check if the desired design is in accordance with any national and/or local building regulations and specifications.

METALLICS

THE PLAY OF SHADOWS AND REFLECTIONS ON A METALLICS FAÇADE GIVES LIVELINESS TO THE BUILDING, RESPONDING TO ITS SURROUNDINGS. DIFFERENT LIGHTING CONDITIONS OR CLOUDS WILL INFLUENCE THE APPEARANCE OF THE FAÇADE AND MAKE IT FLOAT, IN A WAY, ON THE WAVES OF THE CHANGING WEATHER AND TIME. ADDING DEPTH AND THREE DIMENSIONAL ELEMENTS TO METALLICS WILL ENHANCE THIS EXPERIENCE OF INTERACTION AND BRING ATTENTION TO THE FAÇADE.

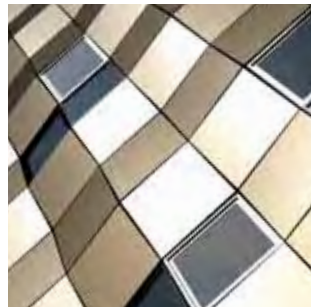

“We are not only selling products, we share our inspiration with the designers by offering innovative products such as Trespa® Meteon® Metallics”.

*David Xiao,
Trespa Sales Manager, China*

NOTE The designs shown are for inspiration only and have not been submitted to specific tests. Actual designs may vary, depending on specific location, regulations and circumstances. Design and fixing systems may influence possible end results. Trespa® Meteon® is CE marked and fully complies with the EU standard. Always check if the desired design is in accordance with any national and/or local building regulations and specifications.

NEW UNI COLOUR

**A22.1.6
ROYAL BLUE**

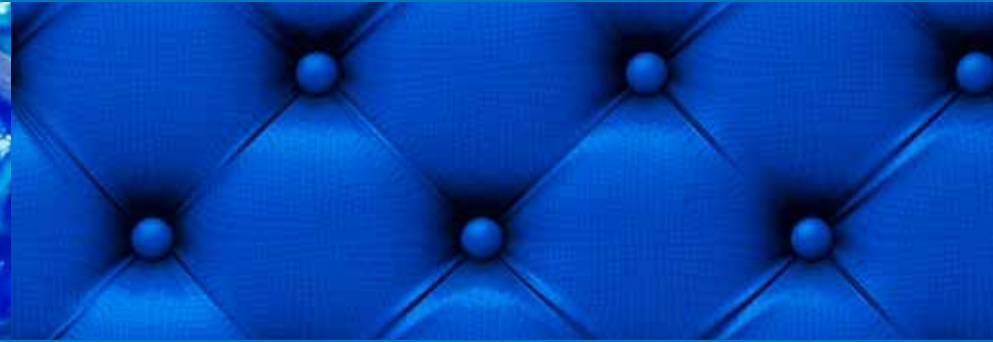

WOOD



“All Trespa® Wood Decors have their own strength, but this must be balanced with their use as an architectural element”.



*Lucas Stevens,
Trespa Architecture & Design*



STONE

**LAUNCH NEW WOOD DECORS AND
NATURALS COLLECTION: OCTOBER 2012**



“The simplicity of a stone is a powerful aesthetic element, a minimal and natural rhythm for everyday life”.

*Filippo Manetti,
Trespa Marketing Director*



TRESPA EVENTS



DESIGN CENTRE **NEW YORK**

Events July - December 2012

AUGUST 15TH

GREEN HOME

EVERY THIRD THURSDAY

TRESPA EVENT

VISIT US AT

62 GREENE STREET
(GROUND FLOOR)
NEW YORK, NY 10012
USA
TEL: +1 212 334 6888
TDC.NEWYORK@TRESPA.COM

OPENING HOURS:

MONDAY – FRIDAY
10.00 – 17.00



DESIGN CENTRE **SANTIAGO**

Events July - December 2012

JULY 12TH

SEPTEMBER 13TH

NOVEMBER 15TH

LUNCH TECHNICAL SEMINAR

EVERY TUESDAY

BREAKFAST FOR PROFESSIONALS IN
ARCHITECTURE, CONSTRUCTION DESIGN
AND ART

VISIT US AT

ELIODORO YÁÑEZ 2831
TORRE A - LOCAL 1
PROVIDENCIA, SANTIAGO
CHILE
TEL: +56 2 4069990
TDC.SANTIAGO@TRESPA.COM

OPENING HOURS

MONDAY – FRIDAY
9.00 – 14.00 | 15.00 – 18.00



DESIGN CENTRE **BARCELONA**

Events July - December 2012

JULY 18TH

AUGUST 16TH

SEPTEMBER 17TH

ARA ARQUITECTURA FAD

SOCIAL NETWORKING

SEPTEMBER 27TH

ARQUIN7 FAD OPENING

ARCHITECTURE FESTIVAL

OCTOBER 22ND

NOVEMBER 19TH

DECEMBER 17TH

ARA ARQUITECTURA FAD

SOCIAL NETWORKING

EVERY THIRD THURSDAY

PROGRAMME ABOUT DESIGN AND
CONSTRUCTION OF BUILDING EXTERIORS.

VISIT US AT

CALLE RIBERA 5
08003 BARCELONA
SPAIN
TEL: +34 (0) 93 295 4193
TDC.BARCELONA@TRESPA.COM

OPENING HOURS

MONDAY - THURSDAY
9.00 – 14.00 | 15.00 – 18.00
FRIDAY 9.00 – 13.00 | 15.00 – 18.00



NEXT ISSUE

INTRODUCTION OF GRAPHICS

Unique eye-catching façades provide a building with character. Thanks to Trespa's latest innovative developments it will be possible to create a surface that repeats or decorative surfaces that do not. The choice is yours.



REFURBISHMENT



Transforming façades for a second life. Trespa® panels can help to create a new and contemporary façade for existing buildings.

Renovation brings more than innovative new looks. It can help to improve a building's insulation and longevity. In this way, Trespa® façades deliver more value.

THERMAL BRIDGING

Meeting thermal insulation requirements. The use of Trespa® Meteor® façade panelling in combination with a timber subframe can make a substantial contribution to minimise the environmental impact of buildings.

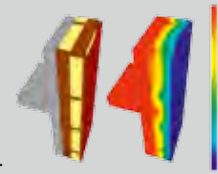

DISCLAIMER This magazine is exclusively intended for general information purposes and is not intended as a recommendation, design, structural calculation, estimate or other warranty or representation for the visitor. Trespa does not warrant and accepts no responsibility for the accuracy and/or completeness of the information in this magazine (including information on the Trespa products) or that the information is suitable for the purpose for which it is consulted by you or otherwise. Customers and third parties must have a professional adviser inform them about (the suitability of) the Trespa products for all desired applications and about applicable laws and regulations. Please note that the views and opinions expressed in this article are those of the authors and do not necessarily reflect the official policy or position of Trespa International B.V. All copyrights and other intellectual property rights and other rights regarding the content of this magazine (including logos, trademarks, service marks, software, databases, text and photographs) are owned by Trespa and/or its licensors. * Trespa, Meteor, Athlon, TopLab, TopLab^{PLUS}, TopLab^{ECO-FIBRE}, Virtuo, Volkern, Trespa Essentials and Mystic Metallics are registered trademarks of Trespa. Trespa is not liable (neither contractual nor non-contractual) for any damage arising from or related to the use of this magazine, including damage resulting from the inaccuracy and/or incompleteness of the information.

DISCLAIMER TRESPA® METEON® This document is part of other Trespa means of communication. The disclaimer that follows is a summary of the applicable full disclaimer. The information provided by Trespa International B.V. ("Trespa") in this document is solely indicative. Trespa is unable to warrant the accuracy and completeness of this information. No rights can be derived from the information provided; the use of the information is at the other party's risk and responsibility. Colours used in Trespa's communications (including but not limited to printed matter) and in samples of Trespa's products may differ from the colours of the Trespa products to be supplied. Trespa's products and samples are produced within the specified colour tolerances and the colours (of production batches) may differ, even if the same colour is used. The viewing angle also influences the colour perception. Metallic panels feature a surface whose colour appears to change based on the direction from which it is viewed. The specified colour stability and colour specifications relate only to the decorative surface of the Trespa products, not to the core material and samples of the Trespa products. Customers and third parties must have a professional adviser inform them about (the suitability of) the Trespa products for all desired applications and about applicable laws and regulations. Trespa is not liable (neither contractual nor non-contractual) for any damage arising from or related to the use of this document, except if and to the extent that such damage is the result of wilful misconduct or gross negligence on the part of Trespa and/or its management. All intellectual property rights and other rights regarding the content of this document (including logos, text and photographs) are owned by Trespa and/or its licensors. * Trespa, Meteor, Athlon, TopLab, TopLab^{PLUS}, TopLab^{ECO-FIBRE}, Virtuo, Volkern, Trespa Essentials and Mystic Metallics are registered trademarks of Trespa.

NEW NATURALS & WOOD DECORS

"All Trespa® Wood Decors have their own strength, but this must be balanced with their use as an architectural element".
New decors available from October 2012.

TRESPA DESIGN CENTRE **SANTIAGO**



Trespa Design Centre Santiago is located in the trendy and artsy commune of Providencia with the objective to foster creativity and spark the imagination of the design professionals responsible for innovative architecture. Find out more about this Trespa Design Centre in Chile.

**FIND OUT MORE
IN THE NEXT ISSUE
WINTER/SPRING 2013**

Colophon

THINK TRESPA IS PUBLISHED TWO TIMES A YEAR BY

TRESPA INTERNATIONAL B.V.
WETERING 20
6002 SM WEEET
TEL: +31 (0) 495 45 83 58
FAX: +31 (0) 495 45 85 70
THINKTRESPA@TRESPA.COM

EDITORIAL

EDITOR IN CHIEF:
MARK STUDHOLME

CONTRIBUTING EDITORS

RIYA PATEL
WILL JONES
CATHELIJNE NUIJSINK
JEANNE TAN

CONTRIBUTING PHOTOGRAPHERS

ROBERT VAN TONGEREN
ANNE HAMERS
THEA VAN DEN HEUVEL
JELMER DE HAAS
JAMES WINSPEAR
TRESPA PHOTOGRAPHY ARCHIVE

GRAPHIC DESIGN & PRODUCTION

CRECS CONCEPT & CREATION
WWW.CRECS.NL

IF YOU WOULD LIKE TO RECEIVE
FUTURE ISSUES FOR FREE,
PLEASE SUBSCRIBE HERE:



TRESPA.COM/UK/MAGAZINE

U2061



TRESPA® METEON®

COLOURING THE WORLD

TRESPA INTERNATIONAL B.V. IS A LEADING INNOVATOR IN THE FIELD OF ARCHITECTURAL MATERIALS, RECOGNISED INTERNATIONALLY AS THE PREMIER DEVELOPER OF HIGH QUALITY PANELS FOR EXTERIOR CLADDING AND DECORATIVE FAÇADES. SINCE ITS FOUNDING IN 1960, TRESPA HAS WORKED CLOSELY WITH ARCHITECTS, DESIGNERS, INSTALLERS, DISTRIBUTORS AND END USERS GLOBALLY. TRESPA BELIEVES IN PRODUCT INNOVATION, COMBINING QUALITY MANUFACTURING TECHNOLOGIES WITH SMART SOLUTIONS FOR ARCHITECTURAL APPLICATIONS.

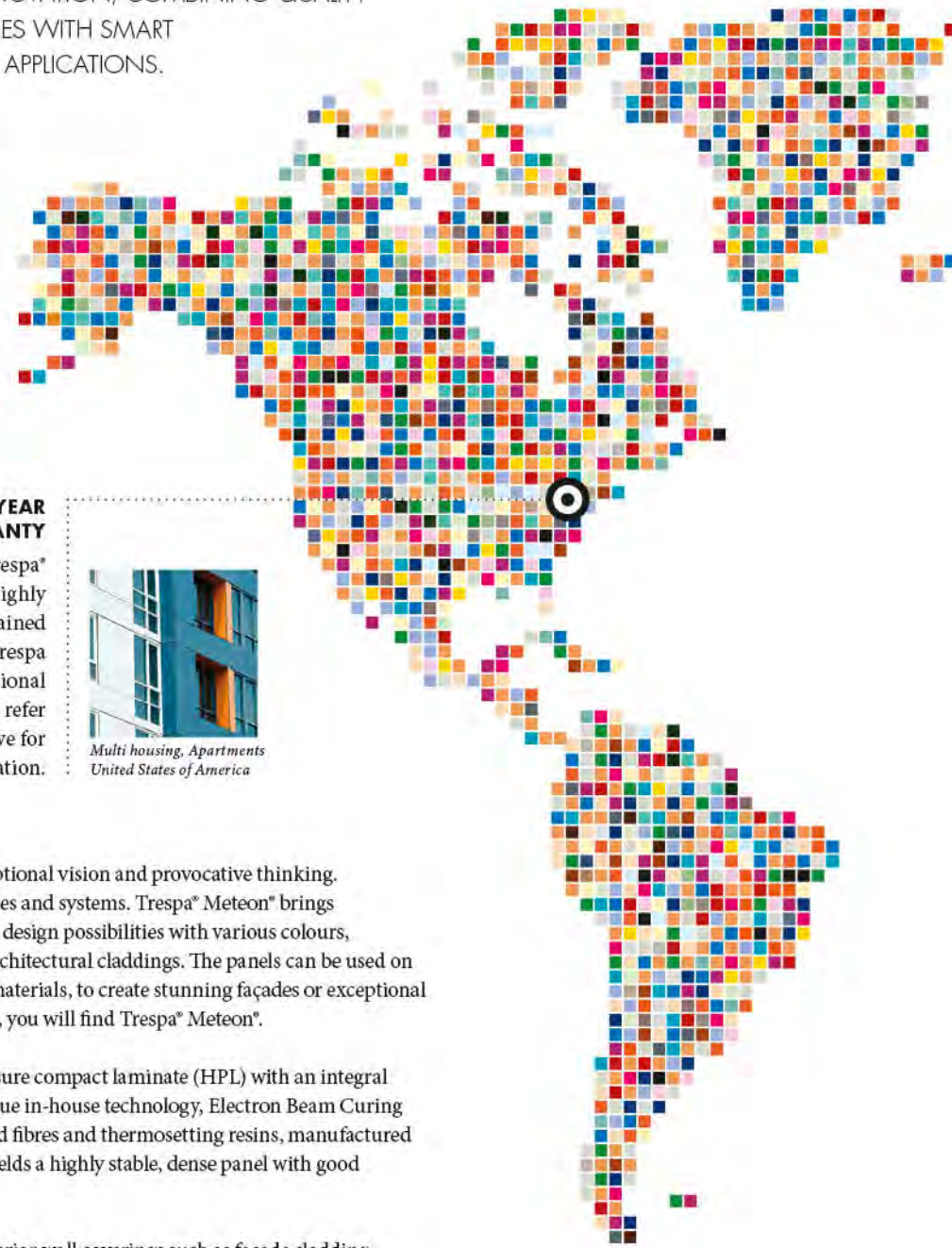

10-YEAR PRODUCT WARRANTY

The unique properties of Trespa® Meteon® panels make them highly durable with a long life of retained appearance. That's why Trespa is offering a ten year conditional warranty of its product. Please refer to your local sales representative for more information.



Multi housing, Apartments
United States of America

WHERE CONCEPT MEETS SOLUTION

Good design starts with inspiration, exceptional vision and provocative thinking. It comes to life with great materials, finishes and systems. Trespa® Meteon® brings compelling aesthetics and nearly limitless design possibilities with various colours, rhythms and depths to next-generation architectural claddings. The panels can be used on their own, or in combination with other materials, to create stunning façades or exceptional highlights. Where concept meets solution, you will find Trespa® Meteon®.

Trespa® Meteon® is a decorative high-pressure compact laminate (HPL) with an integral surface manufactured using Trespa's unique in-house technology, Electron Beam Curing (EBC). The blend of up to 70% wood-based fibres and thermosetting resins, manufactured under high pressures and temperatures yields a highly stable, dense panel with good strength-to-weight ratios.

Trespa® Meteon® stands out in vertical exterior wall coverings such as façade cladding, balcony panelling as well as horizontal exterior ceiling applications.



Public Building | France

COMMITTED TO SAFETY

Trespa is committed to the safety of its processes and products. Two classes of Trespa® Meteon® are available: Standard grade and enhanced Fire-Retardant grade (FR). Please contact your local Trespa representative for local availability.

LOW MAINTENANCE & EASY TO CLEAN

The closed surface of Trespa® Meteon® practically eliminates dirt accumulation, keeping the product smooth and easy to clean.

LONG LIFE PERFORMANCE

Trespa® Meteon® is ideal for prolonged exposure as it stays looking great for many years and needs very little maintenance. Trespa® Meteon® remains the material of choice for architects today, because they can be sure that it will still define the urban landscape tomorrow.



Education | China

SOLID & STURDY

Consistent and high-density throughout, Trespa® Meteon® holds bolts, screws and other mechanical fixings solidly. The panels have good compressive and tensile strength and excellent pullout and impact resistance, yet Trespa® Meteon® is easily machinable and workable like hardwood.



Commercial Office
Australia

RESPECT FOR OUR ENVIRONMENT

Trespa strongly believes that any change should start with the company itself. Trespa's approach towards sustainability starts from an objective and fact based analysis (LCA) of its environmental footprint along the entire value chain. For more information on Trespa's Life Cycle Analysis, please visit trespa.com.



Leisure, Cultural, Sports
Spain

WIDE RANGE OF VIBRANT COLOURS AND FINISHES

Trespa® Meteon® is at the forefront of attractive design and architecture.

The product is available in many standard colours and finishes and even custom-made project colours.

The acclaimed Naturals and Wood Decors collections offer a wide range of wood grains and organic motifs.

WEATHER RESISTANT & COLOUR STABLE

Trespa® Meteon® performs exceptionally well outdoors. Sun and rain will have no significant effect on the panel's surface.

UNI COLOURS

A05.0.0 Pure White	A04.0.0 Cream White	A05.1.0 Papyrus White	A05.1.1 Stone Beige	A08.2.1 Mid Beige	A08.3.1 Stone Grey	NEW A06.7.1 Natural Greige	A08.8.1 Dark Brown
A03.0.0 White	A04.0.1 Pearl Yellow	A07.1.1 Sand	A08.2.3 Salmon	A10.3.4 Terra Cotta	A11.4.4 English Red	A10.4.5 Sienna Brown	A14.7.2 Deep Red Brown
A01.1.0 Pastel Grey	A04.0.2 Pale Yellow	A05.1.2 Champagne	A05.1.4 Sun Yellow	A06.3.5 Ochre	A08.4.5 Rusty Red	A09.6.4 Mahogany Red	A12.6.3 Wine Red
NEW A35.4.0 Cactus Green	A37.2.3 Spring Green	NEW A31.0.6 Majita Green	A04.0.5 Zinc Yellow	A04.1.7 Gold Yellow	A10.1.8 Red Orange	NEW A12.1.8 Passion Red	A12.3.7 Carmine Red
A33.3.6 Brilliant Green	A36.3.5 Turf Green	NEW A37.0.8 Lime Green	A32.2.1 Translucent Green	A21.7.0 Wister Grey	A24.4.1 Steel Blue	A20.5.2 Lavender Blue	A17.3.5 Cyclam
A34.8.1 Forest Green	A32.7.2 Dark Green	A30.3.2 Verdigris	A22.2.1 Bluish Grey	A28.6.2 Mid Green	A26.5.4 Pacific	A22.4.4 Brilliant Blue	A20.2.3 Light Viola
A25.8.1 Anthracite Grey	NEW A21.7.0 Steel Grey	A28.2.1 Aquamarina	A22.3.1 Ocean Grey	A22.2.4 Powder Blue	NEW A22.1.6 Royal Blue	A21.5.4 Cobalt Blue	A22.6.2 Dark Denim
NEW A11.8.0 Ceramic Greige	NEW A05.5.0 Quartz Grey	A21.5.1 Mid Grey	A03.4.0 Silver Grey	NEW A34.0.3 Polar Blue	A20.0.4 Mineral Blue	A20.7.2 Dark Blue	A90.0.0 Black
NEW A06.5.1 Toscana Greige	A10.6.1 Taupe	A16.5.1 Mauve					

PROJECT COLOURS



COLOUR YOUR IMAGINATION

Trespa® Meeon® architectural panels are available in a wide choice of standard colours and effects. To create façades that are even more individual and expressive, Trespa® Meeon® panels can be custom-made in special project colours. For more information please contact your local Trespa representative.

METALLICS

M35.7.1 Malachite Green	M51.0.1 Aluminium Grey	M20.4.2 Northern Light	M24.3.3 Lagoon	M06.4.1 Amber	M05.5.1 Titanium Bronze	M04.4.1 Titanium Silver	
M21.8.1 Graphite Grey	M51.0.2 Urban Grey	M21.3.4 Azurite Blue	M34.3.1 Bottle Green	M40.4.3 Mustard Yellow	M53.0.2 Copper Yellow	M53.0.1 Copper Red	M12.4.2 Garnet Red

Trespa® Meeon® Metallics panels feature a directional coloured surface.

WOOD DECORS

NW01 Loft Grey	NW02 Elegant Oak	NW03 Harmony Oak	NW04 Pacific Board	NW05 Loft Brown	NW06 Montreux Amber	NW07 Montreux Sunglow	NW08 Italian Walnut
NW09 Wenge	NW10 English Cherry	NW11 Santos Palisander	NW12 Natural Bagenda	NW13 Country Wood	NW14 French Walnut	NW15 Milano Sabbio	NW16 Milano Terra
NW17 Milano Grigio	NEW NW18 Light Mahogany	NEW NW19 Dark Mahogany	NEW NW20 Bleached Pine	NEW NW21 Australian Pine	NEW NW22 Slate Wood	NEW NW23 Nordic Black	

Trespa® Meeon® Wood Decors panels feature a directional coloured surface. The grain of Trespa® Meeon® Wood Decors runs the length direction of the panel.

NATURALS

NA05 Erosion	NA06 Patina	NA07 Deep Blue	NA08 Sierra Red	NA09 Oxidation	NA10 Titanic
NEW NA11 French Limestone	NEW NA12 Natural Chalkstone	NEW NA13 Silver Quartzite	NEW NA14 Weathered Basalt	NEW NA15 Indian Terra Cotta	

Trespa® Meeon® Naturals panels feature a directional coloured surface.

SIZES

4270 x 2130 mm (≈ 168 x 83 inch)	3650 x 1860 mm (≈ 143 x 73 inch)	2550 x 1860 mm (≈ 100 x 73 inch)	3050 x 1530 mm (≈ 120 x 60 inch)
-------------------------------------	-------------------------------------	-------------------------------------	-------------------------------------

The large size of this panel allows an efficient machining of the product.

Note: Full size panels feature a squareness tolerance. Please check the Material Property Datasheet for detailed information.

THICKNESSES

	6 mm (≈ 1/4 inch)
	8 mm (≈ 5/16 inch)
	10 mm (≈ 3/8 inch)
	13 mm (≈ 1/2 inch)

VENTILATED FAÇADES

Trespa® Meteon® panels are perfect for use in innovative and functional ventilated façade systems. Used on its own or as a highlight in combination with other materials, Trespa® Meteon® determines the look and underlines the qualities of a building.

Trespa is at the forefront of cutting-edge building techniques. Ventilating façades are more than a design gesture - they provide energy efficient, long-lasting properties.

ADVANTAGES OF VENTILATED FAÇADE SYSTEMS

- A chimney effect draws air through the cavity, aiding in the removal of heat and moisture from rain or condensation.
- The rainscreen also blocks some solar gain and accommodates continuous insulation, improving the overall energy performance of the building.
- Residents and users not only find themselves in a low-maintenance-environment, but the dry and comfortable conditions of the building may also have a positive contribution to the Indoor Environmental Quality (IEQ).



STRONG FOCUS ON SERVICE

As specialist in exterior cladding, Trespa provides knowledge and technical information to aid the design and construction of panelled façades. During all phases of a project, from design and specification to installation, Trespa has a strong focus on service and can provide answers and information to support customers.

Trespa is fully aware that architects wish to realise their specific design going beyond standard solutions. Many customised façades can be realised by offering specific services, especially where Trespa is involved in the early design stage, to give customers detailed advice.



SOLUTION PROVIDING AND VALUE ADDING SERVICES

• PRODUCT TRAINING SESSIONS

For both installers and designers on topics such as the ventilated façade concept, façade installation, product properties and features (for more information check trespa.info).

• TECHNICAL SUPPORT

Trespa can guide its partners to achieve optimal technical solutions for any required façade design with appropriate fixing systems.

• INSTRUCTIONS FOR PANEL HANDLING AND MACHINING

High aesthetical quality requires craftsmanship, the right tools and equipment. Trespa will gladly provide advice on these areas.

• DESIGN SUPPORT

Trespa Studio, a multidisciplinary group working on innovative solutions, supporting architects in façade design and

offering a special “graphics on façades” service (only available for selected countries), that creates unique images with a random repeat (patent pending).

• DESIGN CENTRES

Trespa Design Centres are based in New York, Barcelona, Santiago de Chile and Weert. These are unique collaborative spaces inspiring architects, installers and clients, offering conferences and seminars creating meaningful dialogues with its partners.

• INTERNATIONAL CUSTOMER SUPPORT SERVICE

Trespa Customer Service Desk is available throughout all the regions in which the company is active.

• CUSTOM MADE SOLUTIONS

Many special façade designs have been realised by intensive dialogue with architects to create cost effective, bespoke solutions underpinned by Trespa's customised colours (for projects over 200m² (= 2153 ft²)).



UNI COLOURS

Colour code	Colour name	Satin	Rock	Gloss
A03.0.0	White	☑	☑	☑
A03.1.0	Pastel Grey	☑	☑	☑
A03.4.0	Silver Grey	☑	☑	☑
A04.0.0	Cream White	☑	☑	☑
A04.0.1	Pearl Yellow	☑	☑	☑
A04.0.2	Pale Yellow	☑	☑	☑
A04.0.5	Zinc Yellow	☑	☑	☑
A04.1.7	Gold Yellow	☑	☑	☑
A05.0.0	Pure White	☑	☑	☑
A05.1.0	Papyrus White	☑	☑	☑
A05.1.1	Stone Beige	☑	☑	☑
A05.1.2	Champagne	☑	☑	☑
A05.1.4	Sun Yellow	☑	☑	☑
A05.5.0	Quartz Grey	☑	☑	☑
A06.3.5	Ochre	☑	☑	☑
A06.5.1	Toscana Greige	☑	☑	☑
A06.7.1	Natural Greige	☑	☑	☑
A07.1.1	Sand	☑	☑	☑
A08.2.1	Mid Beige	☑	☑	☑
A08.2.3	Salmon	☑	☑	☑
A08.3.1	Stone Grey	☑	☑	☑
A08.4.5	Rusty Red	☑	☑	☑
A08.8.1	Dark Brown	☑	☑	☑
A09.6.4	Mahogany Red	☑	☑	☑
A10.1.8	Red Orange	☑	☑	☑
A10.3.4	Terra Cotta	☑	☑	☑
A10.4.5	Sienna Brown	☑	☑	☑
A10.6.1	Taupe	☑	☑	☑
A11.4.4	English Red	☑	☑	☑
A11.8.0	Ceramic Greige	☑	☑	☑
A12.1.8	Passion Red	☑	☑	☑
A12.3.7	Carmin Red	☑	☑	☑
A12.6.3	Wine Red	☑	☑	☑
A14.7.2	Deep Red Brown	☑	☑	☑
A16.5.1	Mauve	☑	☑	☑
A17.3.5	Cyclam	☑	☑	☑
A20.2.3	Light Viola	☑	☑	☑
A20.5.2	Lavender Blue	☑	☑	☑
A20.7.2	Dark Blue	☑	☑	☑
A21.1.0	Winter Grey	☑	☑	☑
A21.5.1	Mid Grey	☑	☑	☑
A21.5.4	Cobalt Blue	☑	☑	☑
A21.7.0	Steel Grey	☑	☑	☑
A22.1.6	Royal Blue	☑	☑	☑
A22.2.1	Bluish Grey	☑	☑	☑
A22.2.4	Powder Blue	☑	☑	☑
A22.3.1	Ocean Grey	☑	☑	☑
A22.4.4	Brilliant Blue	☑	☑	☑
A22.6.2	Dark Denim	☑	☑	☑
A23.0.4	Mineral Blue	☑	☑	☑
A24.0.3	Polar Blue	☑	☑	☑
A24.4.1	Steel Blue	☑	☑	☑
A25.8.1	Anthracite Grey	☑	☑	☑
A26.5.4	Pacific	☑	☑	☑
A28.2.1	Aquamarine	☑	☑	☑
A28.6.2	Mid Green	☑	☑	☑
A30.3.2	Verdigris	☑	☑	☑
A32.2.1	Translucent Green	☑	☑	☑
A32.7.2	Dark Green	☑	☑	☑
A33.3.6	Brilliant Green	☑	☑	☑
A34.8.1	Forest Green	☑	☑	☑
A35.4.0	Cactus Green	☑	☑	☑
A36.3.5	Turf Green	☑	☑	☑
A37.0.8	Lime Green	☑	☑	☑
A37.2.3	Spring Green	☑	☑	☑
A41.0.6	Mojito Green	☑	☑	☑
A90.0.0	Black	☑	☑	☑

For available sheet sizes and thicknesses for the above finishes, please check trespa.info for the detailed and up to date Delivery Programme and Material Property Datasheet. Alternatively you can use the Product Selector on trespa.com (after choosing the country where the project is located).

METALLICS

Colour code	Colour name	Satin	Rock	Gloss
M04.4.1	Titanium Silver	☑	☑	☑
M05.5.1	Titanium Bronze	☑	☑	☑
M06.4.1	Amber	☑	☑	☑
M12.4.2	Garnet Red	☑	☑	☑
M20.4.2	Northern Light	☑	☑	☑
M21.3.4	Azurite Blue	☑	☑	☑
M21.8.1	Graphite Grey	☑	☑	☑
M24.3.3	Lagoon	☑	☑	☑
M34.3.1	Bottle Green	☑	☑	☑
M35.7.1	Malachite Green	☑	☑	☑
M40.4.3	Mustard Yellow	☑	☑	☑
M51.0.1	Aluminium Grey	☑	☑	☑
M51.0.2	Urban Grey	☑	☑	☑
M53.0.1	Copper Red	☑	☑	☑
M53.0.2	Copper Yellow	☑	☑	☑

WOOD DECORS

Colour code	Colour name	Satin	Matt
NW01	Loft Grey	☑	☑
NW02	Elegant Oak	☑	☑
NW03	Harmony Oak	☑	☑
NW04	Pacific Board	☑	☑
NW05	Loft Brown	☑	☑
NW06	Montreux Amber	☑	☑
NW07	Montreux Singlow	☑	☑
NW08	Italian Walnut	☑	☑
NW09	Wenge	☑	☑
NW10	English Cherry	☑	☑
NW11	Santos Palisander	☑	☑
NW12	Natural Bagenda	☑	☑
NW13	Country Wood	☑	☑
NW14	French Walnut	☑	☑
NW15	Milano Sabbia	☑	☑
NW16	Milano Terra	☑	☑
NW17	Milano Grigio	☑	☑
NW18	Light Mahogany	☑	☑
NW19	Dark Mahogany	☑	☑
NW20	Bleached Pine	☑	☑
NW21	Australian Pine	☑	☑
NW22	Slate Wood	☑	☑
NW23	Nordic Black	☑	☑

NATURALS

Colour code	Colour name	Matt
NA05	Erosion	☑
NA06	Patina	☑
NA07	Deep Blue	☑
NA08	Sierra Red	☑
NA09	Oxidation	☑
NA10	Titanic	☑
NA11	French Limestone	☑
NA12	Natural Chalkstone	☑
NA13	Silver Quartzite	☑
NA14	Weathered Basalt	☑
NA15	Indian Terra Cotta	☑

FINISHES



TYPES

- ☑ SINGLE SIDED DECORATIVE: decorative side with non decorative black reverse
- ☑ DOUBLE SIDED DECORATIVE: same colour for front and reverse side of the panel
- ☑ VARITOP: decorative side with standard white decorative Satin reverse (A03.0.0)
- ☑ DUOCOLOUR: different colour for front and reverse side of the panel

Visit our new website trespa.com

More inspiration, references, products & technical information.

